



CONFIRMED MINUTES

**Special Council Meeting
Tuesday, 10 January 2023**

Date: Tuesday, 10 January 2023

Time: 5.00pm

Location: Council Chambers, York Town Hall, York

Order Of Business

1	Opening	3
1.1	Declaration of Opening.....	3
1.2	Acknowledgement / Disclaimer	3
1.3	Standing Orders.....	3
1.4	Announcement of Visitors	3
1.5	Declarations of Interest that Might Cause a Conflict	3
1.6	Declaration of Financial Interests	3
1.7	Disclosure of Interests that May Affect Impartiality	3
2	Attendance	3
2.1	Members	3
2.2	Staff	4
2.3	Apologies	4
2.4	Leave of Absence Previously Approved	4
2.5	Number of People in the Gallery at Commencement of Meeting	4
3	Public Question Time	4
3.1	Written Questions – Current Agenda.....	5
3.2	Public Question Time	5
4	Applications For Leave of Absence	5
5	Presentations	5
5.1	Petitions	5
5.2	Presentations	5
5.3	Deputations.....	5
5.4	Delegations’ Reports.....	5
6	Announcements by Presiding Member Without Discussion	5
7	Officer's Reports	6
	SY001-01/23 Development Application: Lot 6 (7) Joaquina Street, York - Change of Use (Community Purpose) & Renovations to Heritage Listed Property	6
	SY002-01/23 Recruitment of a Senior Officer - Executive Manager Infrastructure and Development Services	63
8	Closure	67

**MINUTES OF SHIRE OF YORK
SPECIAL COUNCIL MEETING
HELD AT THE COUNCIL CHAMBERS, YORK TOWN HALL, YORK
ON TUESDAY, 10 JANUARY 2023 AT 5.00PM**

1 OPENING

1.1 Declaration of Opening

Cr Denese Smythe, Shire President, declared the meeting open at 5.00pm.

1.2 Acknowledgement / Disclaimer

The Shire President advised the following:

“The York Shire Council acknowledges the Ballardong people of the Noongar Nation who are the Traditional Owners of this country and recognise their continuing connection to land, water, sky and culture. We pay our respects to all these people and their Elders past, present and emerging.

This meeting is being recorded on a digital audio and visual device to assist with minute taking purposes. The public is reminded that in accordance with Section 6.16 of the Shire of York Local Government (Council Meetings) Local Law 2016 that nobody shall use any visual or vocal recording device or instrument to record the proceedings of Council without the written permission of the presiding member.

I wish to draw attention to the Disclaimer Notice contained within the agenda document and advise members of the public that any decisions made at the meeting today, can be revoked, pursuant to the Local Government Act 1995.

Therefore members of the public should not rely on any decisions until formal notification in writing by Council has been received. Any plans or documents in agendas and minutes may be subject to copyright. The express permission of the copyright owner must be obtained before copying any copyright material.”

1.3 Standing Orders

Nil

1.4 Announcement of Visitors

Nil

1.5 Declarations of Interest that Might Cause a Conflict

Nil

1.6 Declaration of Financial Interests

Nil

1.7 Disclosure of Interests that May Affect Impartiality

Nil

2 ATTENDANCE

2.1 Members

Cr Denese Smythe, Shire President

Cr Ashley Garratt; Cr Pam Heaton; Cr Kevin Trent; Cr Peter Wright

2.2 Staff

Chris Linnell, Chief Executive Officer; Alina Behan, Executive Manager Corporate & Community Services; Sinead McGuire, Executive Manager Infrastructure & Development Services; Vanessa Green, Council & Executive Support Officer

2.3 Apologies

Cr Denis Warnick, Deputy Shire President; Cr Stephen Muhleisen

2.4 Leave of Absence Previously Approved

Nil

2.5 Number of People in the Gallery at Commencement of Meeting

There were three (3) people in the Gallery at the commencement of the meeting.

3 PUBLIC QUESTION TIME

Public Question Time is conducted in accordance with the *Local Government Act 1995* and Regulations. In addition to this the Shire's *Local Government (Council Meetings) Local Law 2016* states:

6.7 Other procedures for question time for the public

- (1) A member of the public who wishes to ask a question during question time must identify themselves and register with a Council Officer immediately prior to the meeting.
- (2) A question may be taken on notice by the Council for later response.
- (3) When a question is taken on notice the CEO is to ensure that—
 - (a) a response is given to the member of the public in writing; and
 - (b) a summary of the response is included in the agenda of the next meeting of the Council.
- (4) Where a question relating to a matter in which a relevant person has an interest is directed to the relevant person, the relevant person is to—
 - (a) declare that he or she has an interest in the matter; and
 - (b) allow another person to respond to the question.
- (5) Each member of the public with a question is entitled to ask up to 2 questions before other members of the public will be invited to ask their questions.
- (6) Where a member of the public provides written questions then the Presiding Member may elect for the questions to be responded to as normal business correspondence.
- (7) The Presiding Member may decide that a public question shall not be responded to where—
 - (a) the same or similar question was asked at a previous meeting, a response was provided and the member of the public is directed to the minutes of the meeting at which the response was provided;
 - (b) the member of the public uses public question time to make a statement, provided that the Presiding Member has taken all reasonable steps to assist the member of the public to phrase the statement as a question; or

- (c) the member of the public asks a question that is offensive or defamatory in nature, provided that the Presiding Member has taken all reasonable steps to assist the member of the public to phrase the question in a manner that is not offensive or defamatory.
- (8) A member of the public shall have 2 minutes to submit a question.
- (9) The Council, by resolution, may agree to extend public question time.
- (10) Where any questions remain unasked at the end of public question time they may be submitted to the CEO who will reply in writing and include the questions and answers in the agenda for the next ordinary Council meeting.
- (11) Where an answer to a question is given at a meeting, a summary of the question and the answer is to be included in the minutes.

Public Question Time commenced at 5.04pm.

3.1 Written Questions – Current Agenda

Nil

3.2 Public Question Time

Nil

As there were no questions, Public Question Time concluded at 5.04pm.

4 APPLICATIONS FOR LEAVE OF ABSENCE

NIL

5 PRESENTATIONS

5.1 Petitions

Nil

5.2 Presentations

Nil

5.3 Deputations

Nil

5.4 Delegations' Reports

Nil

6 ANNOUNCEMENTS BY PRESIDING MEMBER WITHOUT DISCUSSION

The Shire President wished everyone a Happy New Year.

7 OFFICER'S REPORTS

SY001-01/23 DEVELOPMENT APPLICATION: LOT 6 (7) JOAQUINA STREET, YORK - CHANGE OF USE (COMMUNITY PURPOSE) & RENOVATIONS TO HERITAGE LISTED PROPERTY

File Number:	4.3490
Author:	Sharla Simunov, Planner
Authoriser:	Sinead McGuire, Executive Manager Infrastructure & Development Services
Previously before Council:	Not Applicable
Disclosure of Interest:	Nil
Appendices:	1. Plans ↓

NATURE OF COUNCIL'S ROLE IN THE MATTER

Quasi-judicial

PURPOSE OF REPORT

For Council to consider granting development approval to restore and adapt the old brick and iron warehouse-style building located at Lot 6 (7) Joaquina Street, York for use as a community building.

The application is being referred to Council for determination as three (3) written objections were received by the close of the public notification period.

BACKGROUND

Brief History and Existing Development

Lot 6 (7) Joaquina Street, York (hereafter referred to as the property) is 1,147m² in area. Existing development on the property comprises an old 397.9m² brick and iron building (approximately 31.6m in length and 12.6m wide) constructed in early 1910 as the "Court Skating Rink". News articles and advertisements from the era would suggest that the building was used to host a number of community and other types of land uses. Most recently, the building was used to store and sell old machinery.

The building is currently vacant and run-down.

The building is included in the Shire's Heritage Survey as Place No. 129 – Warehouse which includes the following Statement of Significance:

The warehouse, 7 Joaquina Street is significant in representing the diversity of development in York, located in close proximity to the railway station and the main commercial street, it is a rare remaining building of its type within the central York area, and makes a contribution to the history and the historic townscape.

The Proposal

It is proposed to restore and adapt the existing structure for use as a community building. The concept is to create a facility that can be used for a range of functions including fitness classes, meetings and workshops, special events, and co-working events.

The Applicant advises that it is the owners' vision to restore and create a space to support the development of businesses in York and, in so doing, will provide a space that benefit the community through offering classes and workshops.

Plans showing the proposed development are provided at Appendix 1.

COMMENTS AND DETAILS

The proposal was assessed against the relevant provisions of the *Shire of York Local Planning Scheme No. 3* (hereinafter referred to as 'LPS3' or 'the Scheme'), the *deemed provisions for local planning schemes* contained in the *Planning and Development (local planning schemes) Regulations 2015*, and Council's Local Planning Policy No. P6 – Heritage Conservation and Development (LPP6).

The property is zoned 'Regional Centre' in LPS3 where the use class 'community purpose'* is depicted in the Zoning and Land Use Table (Table 3) with the symbol 'A'**.

* In LPS3, community purpose means premises designed or adapted primarily for the provision of educational, social or recreational facilities or services by organisations involved in activities for community benefit;

** 'A' means that the use is not permitted unless Council has exercised its discretion by granting development approval after giving notice in accordance with clause 64 (advertising of planning proposals) of the *deemed provisions for local planning schemes*.

Officers' technical assessment shows that the proposal to refurbish and adapt the long-neglected building for use as a community building, is generally consistent with the relevant provisions of the abovementioned planning instruments. However, Council's special consideration is required in relation to the provision of onsite car parking relevant to the requirements of Schedule 7 (Car Parking) in the Scheme, and whether or not the potential impacts of noise passing from the premises to adjoining properties can be sufficiently ameliorated.

Each of these issues is outlined and discussed below.

Provision of Onsite Car Parking

Clause 1 (a) in Schedule 7 of the Scheme establishes that a person shall not develop or use any land, change the use of land or erect, use or adapt any building unless car parking spaces as specified in the Car Parking Standards Table (also in clause 1 (a)) are provided.

To this end, the application proposes to provide a small carpark incorporating two (2) bays for staff, and one (1) ACROD bay at the rear of the building. The bays will be accessed via a driveway along the west side of the building using the existing crossover to Joaquina Street. It is proposed to seal the driveway and parking spaces with pea gravel over bitumen, draining away from the building to prevent damage to the structure.

Whilst the area at the rear of the building could accommodate up to eight (8) parking bays and an ACROD parking bay, the Applicant advises that this has not been proposed for the following reasons:

- Provision of car parking at the rear of the building would result in paving of almost the whole area preventing its intended development as a garden that complements the use of the building for nurturing community activities including gardening, and visible from inside the building.
- Furthermore, covering the whole rear of the building with sealed car parking would add to the heat absorption ('urban heat sink') which would radiate back into the atmosphere and affect comfort levels within the site and on neighbouring sites. There would be little opportunity to provide any significant planting that would mitigate this if more parking were proposed.
- Due to the narrow side setback and the availability of only one crossover, a two-way driveway to the rear car park can't be accommodated. The potential for conflict between vehicles entering and exiting simultaneously increases with the number of bays provided. By providing parking only for staff and ACROD permit holders, safe access and egress can be easily managed.
- Access is only possible along the south-west side of the building due to the way in which on-street parking has been installed on Joaquina Street, meaning that a one-way circulation

system could not be created to mitigate the risk of conflict between vehicles entering and leaving the site.

Given the Scheme does not have a specific parking standard for 'community purpose' buildings, Council must have regard for the provisions of clause 1 (b) in Schedule 7 of the Scheme which state:

“(b) Where land is to be developed or used for a purpose not mentioned in (a) above, the local government shall determine in each case the required number of car parking bays to be provided on the land having regard to the:

- i) nature of the proposed development;*
- ii) number of employees or others likely to be employed or engaged in the use of the land;*
- iii) anticipated demand for visitor parking;*
- iv) orderly, proper and sustainable planning of the area;*
- v) heritage values of the subject land;*
- vi) parking requirements under the Scheme for uses of a similar nature (if any).”*

With respect to *i)* above, the applicant advises that the venue will be used for a range of community-focused group activities using a booking system. The venue will operate between the hours of 6am and 8pm, further advising that, depending on the activities programmed on any given day, opening may be later and closing earlier.

With respect to *ii)* above, the applicant advises that up to two (2) employees will be onsite at any time.

With respect to *iii)* above, the applicant advises that up to thirty (30) people will take part in activities programmed at the site, most likely associated with group fitness classes which will occur in the morning from 6am to 8am and in the evening from 5pm to 8pm. The parking most likely to be used by patrons is the public carpark at Peace Park opposite the building on Joaquina Street.

In terms of orderly, proper and sustainable planning of the area (*iv)* above), Officers consider that the proposed number of onsite car parking bays, coupled with the availability of on-street parking (approx. 5 bays on both sides of Joaquina Street) and proximity to the public carpark at Peace Park (capable of accommodating 25 – 30 vehicles), will meet the peak demand for car parking at the venue.

With respect to *v)* above, it is considered that a discrete carpark at the rear of the building and a larger landscaped area will be more in keeping with the heritage values of the site than a large, sealed car parking area.

With respect to *vi)* above, there is no parking standard in the Scheme for uses of a similar nature. However, it is noted that the local planning schemes of adjoining local government authorities such as Shire of Northam, Shire of Beverley and Shire of Quairading adopt a parking ratio of 1 parking space per four (4) persons for 'club premises'***. In LPS3, 'club premises' means *premises used by a legally constituted club or association **or other body of persons united by a common interest.***

[**emphasis** added]

*** Officers consider that the use class 'club premises' in the Scheme may be similar/comparable to the use class 'community purpose'.

Therefore, if the abovementioned car parking ratio were to be used as a guide only, then the proposal would trigger the requirement for eight (8) car parking bays if the number of people taking part in activities programmed at the site were capped at thirty (30).

Planning Staff are satisfied that the proposed and existing car parking in the locality is adequate to meet the demand for parking likely to be generated by the proposal.

Noise

One of the submissions received during the public notification period suggests that the accommodation business situated at 75A Avon Terrace would be adversely impacted due to noise generated by the proposed community centre.

While noise and disturbance resulting from the proposed use of the building is a valid planning consideration, it is not expected that noise associated with the activities at the property would reach levels that could be considered offensive or a nuisance. As the *Environmental Protection (Noise) Regulations 1997 (Noise Regulations)* will apply to the activities taking place at the venue, it is the Shire's responsibility to ensure that valid noise complaints are investigated, and appropriate steps are taken to prevent and reduce offensive noise.

Conclusion

It is considered that the proposed activities and hours of operation will not cause any noise or parking issues in the location. The busiest times at the venue will occur before and after standard business hours when demand for public and on-street parking is low.

OPTIONS

Under clause 68(2) of the *deemed provisions for local planning schemes*, Council may determine an application for development approval by –

- (a) *granting development approval without conditions; or*
- (b) *granting development approval with conditions; or*
- (c) *refusing to grant development approval.*

It is recommended Council grants the Applicant Development Approval with conditions (as per option (b) above) for restoration and adaptation of the existing building on Lot 6 (7) Joaquina Street in York for use as a community building.

IMPLICATIONS TO CONSIDER

Consultative

Notice of the proposal was given in accordance with clause 64(4) of the *deemed provisions for local planning schemes* in the following manner:

- Publication of a notice in the York Community Matters on 14 October 2022.
- Publication of an electronic copy of the application on the Shire's website from 14 October 2022 until 28 October 2022.
- Placement of a copy of the application documentation at the Shire office's front counter from 14 October 2022 until 28 October 2022.
- Notifying Elected Members via email on 14 October 2022.
- Notifying adjacent landowners in writing on 14 October 2022 and inviting comment.
- Notifying Council's Heritage Consultant via email on 14 October 2022 (and providing a copy of the application) for comments and advice.
- Notifying the Heritage Council of WA (Department of Planning, Lands & Heritage) via email on 14 October (and providing a copy of the application) for comments and advice.

A public submission period of 14 days ended on 28 October 2022.

Submissions Received

A total of nine (9) submissions were received prior to the close of the notification period, seven (7) of which were received from the public, one (1) from Council's Heritage Consultant, and one (1) submission from the Heritage Council of WA.

Of the seven (7) public submissions, three (3) submissions expressed support for the proposal, three (3) submissions objected to the proposal, and one (1) submission was neither for, nor against the proposal.

A response to each of the submissions is reflected in the Schedule of Submissions table presented below.

TABLE 1: Schedule of Submissions

	Summary of Submission	Objection / Support	Summary of Applicant's Responses to Objections	Officer Comments
Public Submissions				
1	Support the proposed change of use for the property. Reactivation of heritage sites should be encouraged.	Support	-	Noted.
2	Support the concept after studying the plans and information. Submits the proposed community centre will be a great asset to the town and street.	Support	-	Noted.
3	Support the plans for the proposed development.	Support	-	Noted.
4	Proposed community centre would compete with other/similar entities in town and would adversely impact other ratepayers and business owners in the Shire of York.	Objection	Applicant's information is that there is demand for a community facility of this type, not met by current facilities. Advises that there are no other businesses in the street to their knowledge (aside from the hotel on the corner), but given it is a community venue, not sure how it would compete with other businesses.	Noted. The threat of competition, including competition between businesses is not a valid planning consideration and can, therefore, not be taken into consideration.
	Insufficient onsite car parking spaces: shortfall in the provision of parking would cause disruption due to it competing with other commercial and community land uses in the vicinity.		Advises that a rationale for parking is provided in the Applicant's development application report. Further advises the peak hours of operation will be outside standard business hours and there is a public car park opposite, as well as on-street parking. The town centre location supports multiple purpose trips and centralised parking is more efficient in such locations than multiple small car parks at individual premises.	Noted. It is not expected that the proposed activities will cause any parking issues in the location. The busiest times at the venue will occur before and after standard business hours when demand for public and on-street parking is low. The issue regarding the provision of onsite car parking has been addressed under 'Comments and Details' section of this report. The Shire's Planning Staff are satisfied that the proposed onsite and existing car parking (i.e. on-street parking bays and public carpark at Peace Park) in the

	Summary of Submission	Objection / Support	Summary of Applicant's Responses to Objections	Officer Comments
	Submits that the accommodation business situated at 75A Avon Terrace would be adversely impacted due to noise generated by the proposed community centre.		Advises that the types of activities likely to take place in the venue are not intrinsically noisy but the usual environmental noise regulations will apply to activities that take place there.	<p>locality is adequate to meet the demand for parking likely to be generated by the proposal.</p> <p>Noted.</p> <p>It is not expected that noise associated with the activities at the property would reach levels that could be considered offensive or a nuisance. As the <i>Environmental Protection (Noise) Regulations 1997 (Noise Regulations)</i> will apply to the activities taking place at the venue, it is the Shire's responsibility to ensure that valid noise complaints are investigated, and appropriate steps are taken to prevent and reduce offensive noise.</p>
5	<p>Submitter's residential unit backs on to the driveway of the site. The proposal will negatively impact upon the value of his property.</p> <p>Parking is insufficient and use of the land and building for a community centre will compete with other nearby land use activities.</p>	Objection	<p>Advises that there is no reason to expect that community activities would have an adverse impact on neighbours. Further advises that property resale value may also increase as a result of the currently derelict building being restored. Advises that an objection based on the impact on property value is not in a valid planning consideration.</p> <p>Refer comments above (#4, second point)</p>	<p>Noted.</p> <p>The effect on property value is not a relevant planning consideration and cannot be taken into account in town planning decisions.</p> <p>Noted.</p> <p>It is not expected that the proposed activities will cause any parking issues in the location. The busiest times at the venue will occur before and after standard business hours when demand for public and on-street parking is low.</p> <p>The issue regarding the provision of onsite car parking has been addressed under 'Comments and Details' section of this report. The Shire's Planning Staff are satisfied that the proposed onsite and existing car parking (i.e. on-street parking bays and public carpark at Peace Park) in the locality is adequate to meet the demand for parking likely to be generated by the proposal.</p>

	Summary of Submission	Objection / Support	Summary of Applicant's Responses to Objections	Officer Comments
	Generally opposes development of any kind to 7 Joaquina Street.		-	Noted. Not a valid planning consideration.
6	Neither for nor against the proposal, but notes that proposed use of the building for 'entertainment purposes' may result in noise problems.	Neither	Refer comments above (#4, third point)	Noted. It is not expected that noise associated with the activities at the property would reach levels that could be considered offensive or a nuisance. As the <i>Environmental Protection (Noise) Regulations 1997 (Noise Regulations)</i> will apply to the activities taking place at the venue, it is the Shire's responsibility to ensure that valid noise complaints are investigated, and appropriate steps are taken to prevent and reduce offensive noise.
7	The proposed community centre would, if approved, compete directly with other venues in York.	Objection	Refer comments above (#4, first point)	Noted. The threat of competition, including competition between businesses is not a valid planning consideration and can, therefore, not be taken into consideration.
Heritage Council of WA (Department of Planning, Lands & Heritage (DPLH))				
8	The Heritage Council previously identified the Precinct as a place warranting assessment for possible entry in the State Register of Heritage Places; however, a full assessment of its cultural heritage significance has not yet been undertaken.	Support	-	Noted.
	The general approach to works should be to retain and repair existing fabric and only replace to match where fabric is beyond repair.		That is the intention.	Noted & agree.
	Removal of external paint from masonry/stonework surfaces shall be undertaken using non-abrasive method.		That is the intention.	Noted & agree.
	Modifications to the entry opening should not involve removal of brickwork, and existing door should be pinned open internally.		Although supported in principle, keeping the existing doors in their current condition (clad with old metal sheeting) pinned open internally would obscure the beautiful unpainted	Noted & agree with the Applicant's response.

	Summary of Submission	Objection / Support	Summary of Applicant's Responses to Objections	Officer Comments
			brickwork on the interior, which is intended to be a feature of the interior aesthetic. A compromise by which the frame is retained but the sheeting is removed would be far preferred. The sheeting is unlikely to be original in any case.	
Heritage Consultant (Leigh Barnett Heritage)				
9	The proposal is supported subject to the following: Retention of the place is desirable and commended. The proposed use is acceptable. The use of short sheet galvanised cladding to the walls and roof is desirable and supported. The advice of the Heritage Council of WA that existing fabric should be retained and repaired wherever possible is reiterated.	Support	Noted.	Noted & agree.
	Restoration of the front brick facade should be done with care and removal of paint should be by non-abrasive methods as these can damage the brickwork and mortar. In addition, the use of lime-based mortars is required if it is determined that the original mortar is lime-based. The use of cement-rich mortars on brick walls where the bricks are 'softer' than modern bricks can result in damage due to rising damp and salt attack. In this regard, care should also be taken to ensure that stormwater drainage is directed away from the building's brick walls.		Noted. This is the intention.	Noted & agree.
	Modifications to the front entry way are supported subject to the retention of the existing sliding doors (pinned open internally as advised by the Heritage Council) and no removal of any existing brickwork.		Noted. This is the intention.	Noted & agree.
			Noted. This will, however, compromise other aspects of the building's appearance. Refer corresponding comment to Heritage Council of WA.	Noted & agree with the Applicant's response to Heritage Council of WA above.

StrategicStrategic Community Plan 2020-2030

Goal 4: Built for Lifestyle and Resilience

To have a built environment which supports community, economy, and the environment, respects the past, and creates a resilient future.

Policy Related

Council's Local Planning Policy No. P6 – Heritage Conservation and Development (LPP6) is relevant to the proposal as the subject property is located within the Central York Heritage Area.

One of the primary objectives of LPP6 is to ensure that new development does not adversely impact the cultural values, significance and character of heritage places and areas.

Financial

There are no direct financial implications for the Shire associated with the recommendations of this report.

Legal and Statutory

- *Planning and Development Act 2005*
- *Shire of York Local Planning Scheme No. 3*
- *Planning and Development (Local Planning Schemes) Regulations 2015 (Schedule 2)*
- *Planning and Development Regulations 2009*
- *Heritage Act 2018*

Risk Related

A risk assessment of the proposal has been undertaken, and there was no medium to high risks identified with the proposal. Standard appeal rights to the State Administrative Tribunal are available to the Applicant if they are aggrieved by any final determination by Council.

Workforce

The scope of this report is managed within current operational capacity.

VOTING REQUIREMENTS

Absolute Majority: No

RESOLUTION**010123****Moved: Cr Ashley Garratt****Seconded: Cr Kevin Trent**

That Council, pursuant to clause 68(2)(b) of the deemed provisions of local planning schemes, grants development approval to adapt the existing building at Lot 6 (7) Joaquina Street, York for community purposes, subject to the following conditions:

General Conditions

- 1. The development hereby permitted shall substantially commence within two (2) years from the date of this decision notice.**
- 2. The development hereby approved shall be undertaken in accordance with the signed and stamped, Approved Development Plan(s) (enclosed), including any notes placed thereon in red by the Shire and except as may be modified by the following conditions.**
- 3. The stormwater shall be discharged in a manner so that there is no discharge onto the adjoining properties to the satisfaction of the local government.**
- 4. Any outdoor lighting is to be designed, baffled and located to prevent any increase in light spill onto the adjoining properties.**
- 5. Noise emissions must comply with the *Environmental Protection (Noise) Regulations 1997* (Noise Regulations) at all times.**
- 6. The removal of external paint from the masonry/stonework surfaces shall be undertaken using a non-abrasive method and the use of lime-based mortars is required if it is determined that the original mortar is lime-based.**
- 7. The modifications to the entry opening shall not involve removal of brickwork, and the existing door frame shall be pinned open internally.**
- 8. Except with the prior written consent of the local government, the use permitted by this approval must operate only between the following times:**

Monday – Friday: 06:00 – 20:00

Saturday: 07:00 – 13:00

Sunday: 09:00 – 18:00

Public Holidays: No Activity

Condition to be met prior to commencement of development

- 9. Prior to commencement of development, a detailed landscaping plan is to be submitted to and approved by the local government.**

Conditions to be met prior to occupation of development

- 10. Prior to occupation of the development, the car parking, and vehicle access and circulation areas shown on the approved site plan, including the provision of universally accessible (disabled) car parking, is to be constructed, drained, and line marked to the satisfaction of the local government.**
- 11. Prior to occupation of the development, landscaping is to be completed in accordance with the approved plans or any approved modifications thereto to the satisfaction of the local government.**

Conditions requiring ongoing compliance

- 12. All car parking areas, and vehicle access and circulation areas are to be maintained and available for car parking, and vehicle access and circulation on an ongoing basis to the satisfaction of the local government.**

13. All landscaped areas are to be maintained on an ongoing basis to the satisfaction of the local government.

ADVICE NOTES:

- Note 1:** If the development the subject of this approval is not substantially commenced within a period of two (2) years, or another period specified in the approval after the date of determination, the approval will lapse and be of no further effect.
- Note 2:** Where an approval has lapsed, no development must be carried out without the further approval of the local government having first been sought and obtained. Should the approval period lapse, a new planning application with relevant retrospective fees may be required by the Shire of York.
- Note 3:** If the applicant or owner is aggrieved by this determination, there is a right of review by the State Administrative Tribunal in accordance with the *Planning and Development Act 2005 Part 14*. An application must be made within twenty-eight (28) days of the determination.
- Note 4:** In accordance with the provisions of the *Building Act 2011*, and *Building Regulations 2012*, an application for a building permit may be required to be submitted, and approved by the Shire of York, prior to the commencement of the development hereby permitted. Please contact the Shire's Building Surveyor for further information.
- Note 5:** This is a development approval of the Shire of York under its Local Planning Scheme No. 3. It is not a building permit or an approval to commence or carry out development under any other law. It is the responsibility of the applicant/landowners to obtain any other necessary approvals, consents, permits and licenses required under any other law, and to commence and carry out development in accordance with all relevant laws.

CARRIED: 5/0

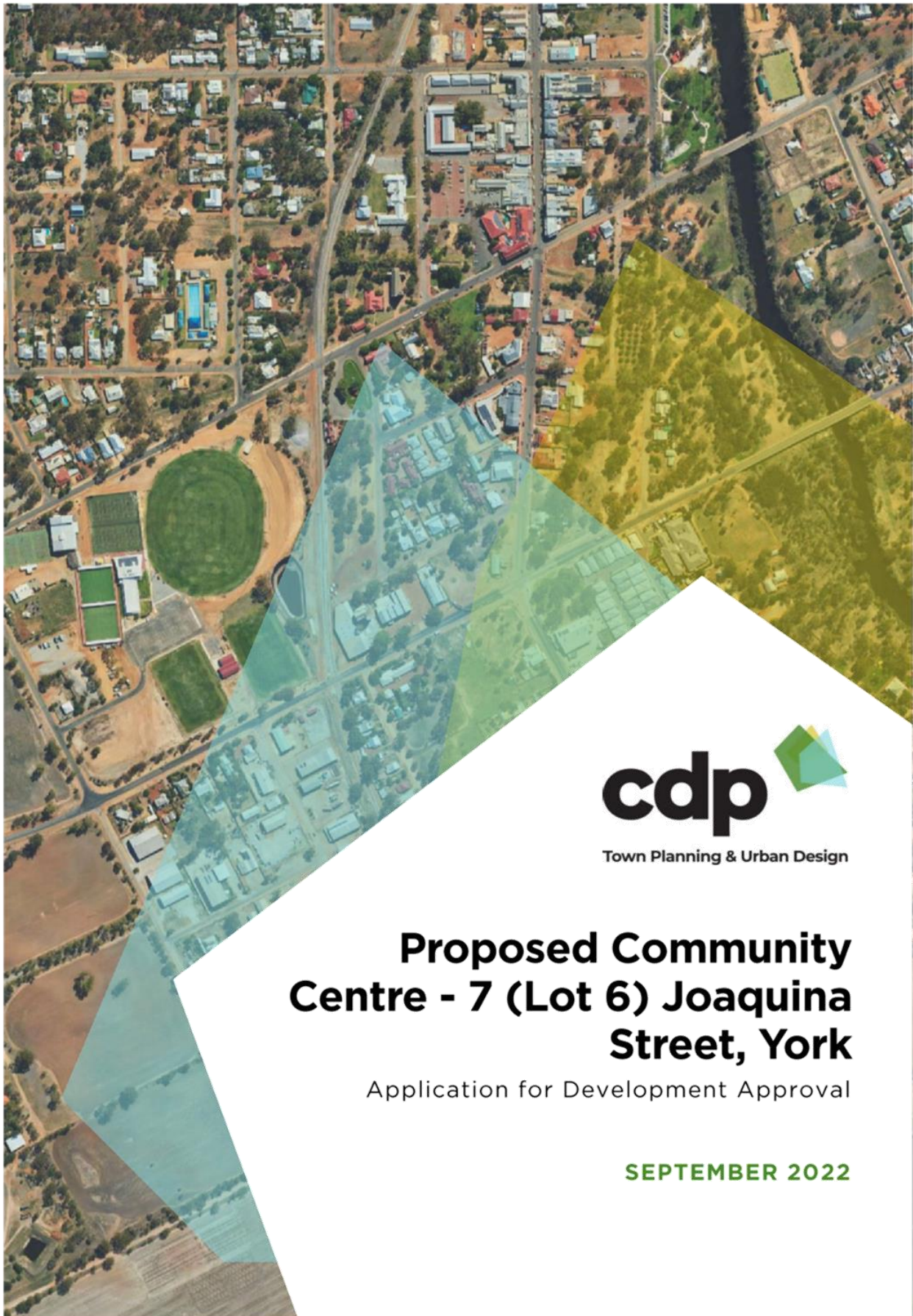

Proposed Community Centre - 7 (Lot 6) Joaquina Street, York

Application for Development Approval

SEPTEMBER 2022

Proposed Community Centre - 7 (Lot 6) Joaquina Street, York.

Application for Development Approval

SEPTEMBER 2022

Prepared by. CDP Town Planning & Urban Design
2/464 Murray Street
PERTH WA 6000

p. +61 8 6333 1888
e. info@cdpaus.com.au
w. www.cdpaus.com.au

Prepared for.
7 Joaquina Street
York WA 6302

DOCUMENT STATUS

Version	Comment	Prepared	Reviewed	Issued
1	Draft for client review	DM	RM	14/09/2022
2	Lodgement	DM	RM	20/09/2022

DISCLAIMER & COPYRIGHT

This document was commissioned by and prepared for the exclusive use of our Client. It is subject to and issued in collaboration with the agreement between CDP and our Client.

CDP acts in all professional matters as a faithful advisor to its clients and exercises all reasonable skill and care in the provision of professional services. The information presented herein has been compiled from several sources using a variety of methods. Except where expressly stated, CDP does not attempt to verify the accuracy, validity or comprehensiveness of this document, or the misapplication or misinterpretation by third parties of its content.

This document cannot be copied or reproduced in whole or part for any purpose without the prior written consent of CDP.

Contents.

- 1. Introduction1**
- 2. The Property1**
 - 2.1 Legal Description..... 1
 - 2.2 Existing Development 1
 - 2.3 Site Context 4
- 3. Heritage 6**
 - 3.1.1 History 6
 - 3.1.2 Heritage Listing 7
- 4. Planning Framework 7**
 - 4.1 Local Planning Scheme No. 3..... 7
 - 4.1.1 Zoning & Permissibility 7
 - 4.1.2 Heritage Protection 8
 - 4.1.3 Local Planning Policy Heritage Conservation & Development..... 8
- 5. Proposed Development 8**
 - 5.1 Use 8
 - 5.2 Building Modifications 9
 - 5.3 Car Parking 9
 - 5.3.1 Proposed Parking 9
 - 5.3.2 Parking Requirements 10
 - 5.4 Landscaping..... 11
 - 5.5 Servicing 11
 - 5.5.1 Wastewater 11
 - 5.5.2 Electricity 11
 - 5.5.3 Stormwater 11
 - 5.5.4 Bin Stores..... 11
- 6. Conclusions 11**

1. Introduction

This application for planning approval proposes to restore and adapt the vacant brick and iron building at 7 Joaquina Street for use as a community building.

The concept is to create a space that can be used by groups and individuals for a range of functions such as:

- Fitness classes (eg. yoga, pilates)
- Meetings and workshops (eg. local clubs and businesses)
- Special events (eg. exhibitions, workshops)
- Co-working events (eg. business incubator)

This facility will meet demand in York for a local meeting place, with several groups having expressed interest in using the space if the application is successful.

The building is currently vacant and run-down but is an important element in the evolving story of Joaquina Street and the wider Central York Heritage Area. Restoration will make a positive contribution to the streetscape.

The proponent is a long-term member of the York community who has already successfully renovated heritage properties in both York and Perth. The intention is to create a beautiful, multifunctional space that can be hired at affordable rates by community groups and businesses.

2. The Property

2.1 Legal Description

The subject land is described as Lot 6 on Plan 63, the subject of Certificate of Title 1857/293. A copy of the Certificate of Title is included at **Appendix 1**.

The lot is approximately 1,147m² in area with a frontage to Joaquina Street of about 20 metres.

2.2 Existing Development

An old brick and iron warehouse-style building is situated on the site but otherwise the site is vacant and cleared of vegetation except for a large tree close to the rear and side boundaries.

The building has a brick façade built to the street boundary. The façade has been painted but the 'garden bond' brickwork pattern can be perceived through the paint. Apart from the façade, the rest of the building is clad in unlined corrugated iron sheets. The louvred hipped (gambrel) roof and all other walls are clad in corrugated iron sheets. Historic aerial photography indicates that a hipped-roof rear addition has been recently removed.

Vehicle access to the site was previously achieved via driveways on each side of the building and centrally through the sliding front door. Only the central and southern accesses were retained when the Shire of York undertook work in Joaquina Street in 2018. An on-street carparking bay now prevents vehicle access along the northern side of the building.

The building has been vacant for some time and is not presently habitable. Photographs from the real estate website advertising the building for sale earlier this year show the current state of the building. These are reproduced in **Figure 1**.

Figure 1. Images of Current Condition

Images sourced from <https://www.realestate.com.au/property/7-joaquina-st-york-wa-6302> 14 June 2022



Proposed Community Centre - 7 (Lot 6) Joaquina Street, York | **cdp 2**



3 cdp | Proposed Community Centre - 7 (Lot 6) Joaquina Street, York

2.3 Site Context

The subject land is located on the south side of Joaquina Street, opposite Peace Park and the adjacent public car parking area. Peace Park occupies part of Lot 25 and Lots 26 and 27 and is owned by the Shire. The car park occupies Lot 24 and part of Lot 25.

Refer to **Figure 2** for a local context plan.

Joaquina Street has always been and continues to be a very diverse street in terms of land use. It was constructed circa 1886 to connect to the newly completed railway station, and the only building on it then was the Imperial Hotel facing Avon Terrace. Various land uses have been associated with the street historically, including the Shire's meat inspection room, Oddfellows (later Freemasons) hall, Dalgety and Co saleyards, an aerated water factory, the Court Skating Rink, Infant Health Centre, and residences. The Shire has always owned several lots in the street.

The Shire offices occupy the land behind the Town Hall and the former Infant Health Centre on Lot 7, adjacent to and east of the subject land, has been demolished for the construction of Shire staff parking. Lot 70, adjacent to the west boundary of the subject land, is a residential lot with eight grouped dwellings and three crossovers to Joaquina Street. On the south-west corner of Joaquina and Railway Streets are grouped dwellings owned by the State Housing Commission, and on the north-west corner is the St John's Ambulance York Sub-Centre.

To the rear, Lot 17 has frontage to Broome Street and is occupied by a heritage listed Federation Queen Anne style residence once used as the private Stratford House Maternity Hospital.

Other than the Imperial Hotel and the Town Hall on the corner of Avon Terrace, and Oddfellows Hall on Lot 202, all buildings in the street are single storeyed.



3. Heritage

3.1.1 History

Documentary evidence suggests that the building on Lot 6 Joaquina Street was built in early 1910 as the "Court Skating Rink", which was opened on 20 April 1910. A newspaper article in November 1909 reported that "a block of land situated in Joaquina Street, and next to the Oddfellows Hall, has been purchased by the Crystal Palace Skating Rink management, upon which it is intended to erect a large hall for the purpose of holding entertainments". In February 1910 it was reported that plans had been submitted for "a Skating Rink to be erected in Joaquina Street...to consist of a brick front with weatherboard sides and an iron roof".

The skating rink is mentioned in numerous articles and advertisements from the early part of the 20th Century, suggesting a long history of the building hosting community uses, such as amateur opera and theatre, fancy dress balls, school concerts, moving pictures, and political rallies (for example see **Figure 3**).

Although the building's use as a skating rink seems to have been short-lived, it continued to be referred to as the 'old skating rink' for many years. By 1913 the Alpha Motor and Engineering Works was advertising its address as the "Old Skating Rink" in Joaquina Street. In 1930, St Leon's Circus advertised a show to take place "next to old Skating Rink". By the late 1930's the Town Council was receiving complaints about its condition, and it was described as "dilapidated". In 1943 a notice was issued for its "repair or demolition within 21 days" because it was "an eyesore", however in 1948 an application was made to "convert the old skating rink to a residence". The building has been used for auctions, machinery storage, chaff storage, and possibly an ice works. It was most recently used to store and sell old machinery.

The building is currently vacant and in poor to fair condition, requiring work to be made habitable.

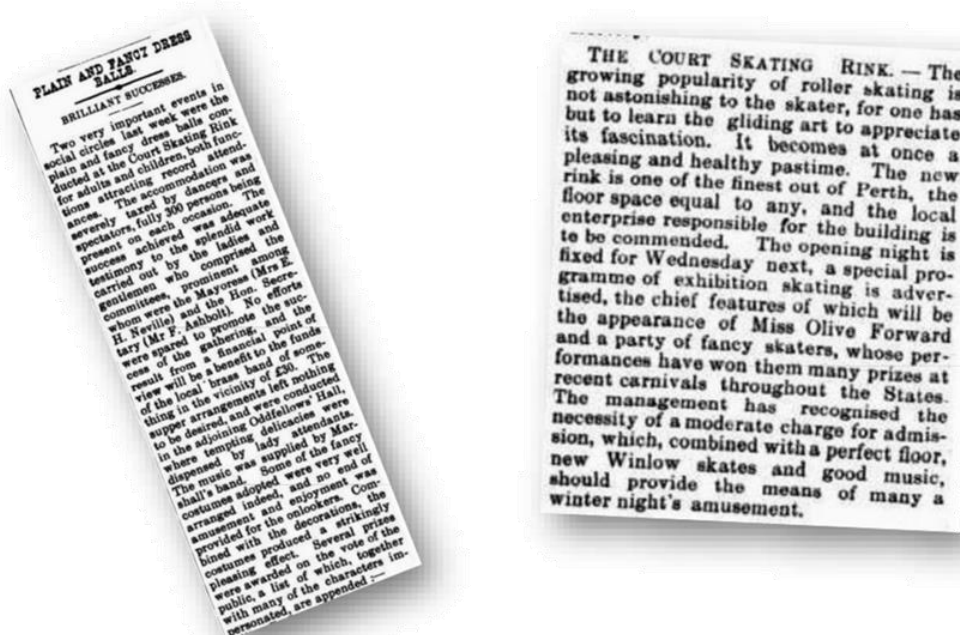

Figure 3. Extracts Eastern Districts Chronical 15 April & 22 July 1910

3.1.2 Heritage Listing

The building was identified in the Shire's **Heritage Survey** as Place No. 129 – Warehouse. The related Statement of Significance is:

The warehouse, 7 Joaquina Street is significant in representing the diversity of development in York, located in close proximity to the railway station and the main commercial street, it is a rare remaining building of its type within the central York area, and makes a contribution to the history and the historic townscape.

The subject land is situated within the Central York Precinct, which is on the **Heritage List** under *Local Planning Scheme No. 3* (refer to **4.1.2**). 7 Joaquina Street is identified as a significant place within this precinct but is not on the list in its own right. This means that the primary consideration in determining this application for development approval is the impact of the proposal on the building's contribution to the precinct.

Verbal advice was received from the Department of Planning, Lands and Heritage (DPLH) that the Central York Precinct is a 'priority for assessment' for possible entry onto the **State Heritage Register**. Therefore, referral of this application to DPLH is expected.

4. Planning Framework

4.1 Local Planning Scheme No. 3

4.1.1 Zoning & Permissibility

The subject land is zoned 'Regional Centre' in LPS 3. The objectives of the 'Regional Centre' zone are to:

- Provide a range of services and uses to **cater for both the local and regional community**, including but not limited to specialty shopping, restaurants, cafés and entertainment.
- Ensure that there is provision to transition between the uses in the regional centre and the surrounding low density residential areas to ensure that the impacts from the operation of the regional centre are minimised.
- Provide a broad range of employment opportunities to **encourage diversity and self-sufficiency** within the Centre.
- Encourage high quality, pedestrian friendly, street-orientated development that **responds to and enhances the key elements of the Regional Centre**, to develop areas for public interaction and support the provision of public transport.
- Ensure the provision of residential opportunities within the Regional Centre including high density housing that supports the role of the regional centre and meets the needs to the community.
- To encourage the **growth of tourism and cultural businesses** and experiences in York.
- To **preserve the unique qualities of the York town centre** as a heritage place, and achieve high quality development that complements heritage character.

The proposed land use falls within the definition of 'Community Purpose'. The LPS 3 definition reads:

Community Purpose means premises designed or adapted primarily for the provision of educational, social, or recreational facilities or services by organisations involved in activities for community benefit.

Community purpose uses are classified as 'A' in the Regional Centre Zone, meaning that the use is not permitted unless the local government has exercised its discretion by granting development approval after giving notice in accordance with clause 64 of the deemed provisions. Clause 64 relates to advertising applications.

4.1.2 Heritage Protection

Because the building is within a precinct that has been entered on the Shire's Heritage List under Part 3 of the Deemed Provisions of LPS 3 relating to heritage protection, consideration of this proposal will take into consideration the reasons for the listing.

Clause 12 of Part 3 allows the local government to vary any site or development requirement specified in the Scheme to facilitate the built heritage conservation of a place on the Heritage List or to enhance or preserve heritage values in a heritage area.

4.1.3 Local Planning Policy Heritage Conservation & Development

This local planning policy (LPP) applies inter alia to all development within the Central York Heritage Area. One of its primary objectives is to ensure that new development does not adversely impact the cultural heritage values, significance and character of heritage places and areas.

The proposed use is not residential, therefore Part 4 of the LPP relating to commercial development applies. The policy provides guidance on various built form elements required for new development including modifications to existing development. It also outlines additional application requirements that may be required for proposals that will "have a substantial impact on the exterior fabric of a place of considerable or some/moderation contribution."

This application addresses the relevant concerns of the LPP, however other than appropriate and long overdue repairs, including removal of paint from the face brick (if practical without causing damage to the bricks), the proposal can't be deemed to have a "substantial impact" on the exterior fabric of the building.

5. Proposed Development

5.1 Use

It is proposed to use the building and land as a multipurpose community building that will be available for hire at affordable rates for businesses offering such activities as yoga, pilates, art classes, creative writing, etc. Also envisaged is the use of the space where people can 'drop in' to participate in creative activities like knitting, crochet, painting, clay modelling, and fabric dyeing, for the price of a donation.

The proposed venue would also provide meeting space and a place for mentoring and discussion of business development and local events.

In short, the owners' vision is to restore and create a beautiful, nurturing space to support the development of businesses in York. At the same time, the space will provide a benefit to the community through offering classes and workshops.

The building will accommodate no more than 30 people at any time, with far fewer likely to be in attendance most of the time.

5.2 Building Modifications

Plans certified by a structural engineer and showing the proposed development are provided at the end of this report.

The building is in fair to poor condition at present, though with a reasonably high degree of authenticity. No documentary evidence has been identified to confirm the exact origins and purpose of the building although there is strong evidence to suggest that it was originally built as a roller-skating rink and the simple form is similar to photographs of similar facilities built elsewhere in Australia around the same time (refer to **3.1.1**). If so, then it may have originally had weatherboard walls but these had been replaced with corrugated iron sheeting very early on as reports from the late 1930's referring to its "dilapidated" condition also mention "flapping iron" that was generating complaints from neighbours. It is clear that there have been few major modifications to the structure and few changes of any sort for many years until the recent removal of an old rear addition by the previous owner.

It is proposed to restore the original face brick façade of the building by carefully removing the paint to avoid damaging the bricks. This will be done by an experienced professional. The top few courses of bricks will be removed then re-laid and repointed due to failure in the existing mortar as a result of poorly installed roof drainage in the past. The short-sheet corrugated iron cladding of the roof and walls will be repaired or replaced as necessary, including the introduction of highlight windows in the side walls to introduce natural light and ventilation while having minimal impact on the form and external appearance of the building. Roof plumbing will be replaced with appropriately profiled new gutters and downpipes.

The proposed hipped-roof addition will replicate the form of the structure removed by the previous owner and still visible in aerial photography (for example **Figure 2**).

The existing corrugated iron sliding 'barn' doors in the front elevation are heavy and unsuitable for daily pedestrian access. It is proposed to retain the opening but to install new double doors with side lights and high lights, with fixed weatherboard infill extending from the top of the highlights to the existing timber lintel.

Internally, all walls but the front brick wall will be painted white. The interior of the front brick wall is unpainted (refer to photo included in **Figure 1**). Some restumping and replacement of damaged timber will be required. A burnished concrete floor will be installed.

Amenities including male and female toilets, disabled toilet and shower, and small kitchen will be installed towards the rear, leaving most of the space open in keeping with the original character of the building. Some workstations are proposed near the front of the building. A verandah will be built on the rear of the building, accessed by new doors in the rear wall. A lockable storeroom will be provided at one end of the verandah, and a trough and bench at the other.

5.3 Car Parking

5.3.1 Proposed Parking

There is nowhere other than behind the building for any on-site parking to be provided.

It is proposed to provide a small car park incorporating two staff bays and one ACROD bay at the rear of the building, accessed by a driveway along the west side using the existing crossover to

Joaquina Street. The driveway and parking will be sealed with pea gravel over bitumen, draining away from the building to prevent damage to the structure.

5.3.2 *Parking Requirements*

LPS 3 does not have a specific requirement for parking for community purpose buildings. Instead, the Shire is to determine the required number of car parking bays to be provided on the land having regard to the:

- i) nature of the proposed development;
- ii) number of employees or others likely to be employed or engaged in the use of the land;
- iii) anticipated demand for visitor parking;
- iv) orderly, proper and sustainable planning of the area;
- v) heritage values of the subject land;
- vi) parking requirements under the Scheme for uses of a similar nature (if any).

In response to these considerations, the following is noted:

- i) The development will be used as a venue for a range of community-focussed group activities using a booking system. Operating hours are expected to be 06:00 – 20:00, Depending on the activities programmed on any given day, opening may be later and closing earlier.
- ii) Up to two employees will be on site at any time.
- iii) Up to 30 people will take part in activities programmed at the space. This number is likely to be associated with group fitness classes such as yoga and pilates, which are typically programmed for early mornings and evenings (06:00 – 08:00 and 17:00 – 20:00). The parking most likely to be used by visitors is the public parking at Peace Park, opposite the building.
- iv) In terms of orderly and proper planning, the proposed parking provision is considered adequate for the proposed development considering its town centre location, the close proximity of a public car park, the availability of on-street parking, and the heritage values and proposed use of the building. There is no on-site parking at present.

Whilst the back yard area could potentially accommodate up to eight parking bays and a ACROD parking bay, this is not proposed for several reasons:

- Provision of car parking at the rear of the building would result in paving of almost the whole area, preventing its intended development as a garden that complements the use of the building for nurturing community activities including gardening, and visible from inside the building.
- Furthermore, covering the whole rear of the building with sealed car parking would add to heat absorption ('urban heat sink') which would radiate back into the atmosphere, and affect comfort levels within the site and on neighbouring sites. There would be little opportunity to provide any significant planting that would mitigate this if more parking were proposed.
- Due to the narrow side setback and the availability of only one crossover, a two-way driveway to a rear car park can't be accommodated. The potential for conflict between vehicles entering and exiting simultaneously increases with the number of bays

provided. By providing parking only for staff and ACROD permit holders, safe access and egress can be easily managed.

- Access is only possible along the south-west side of the building due to the way in which on-street parking has been installed in Joaquina Street, meaning that a one-way circulation system could not be created to mitigate the risk of conflict between vehicles entering and leaving the site.
- v) The heritage values of the land have been described elsewhere in this report. There is no documentary evidence to describe how the curtilage of the building was used historically other than for the storage of machinery and open area - sometimes grassed and sometimes cleared ground. Available aerial photography (earliest is 1960) seems to suggest that the rear of the site was unfenced on the western side until the units on the neighbouring site were built circa 2007. The proposed small car park and large garden is more in keeping with the heritage values than a large hard paved parking area.
- vi) There is no similar land use specified in LPS 3, but within the Regional Centre zone the ratio of parking required for listed land uses is lower than outside the Regional Centre. This is because within town centres there is more likelihood of multi-destination trips (ie: people park once and visit several destinations). This is also likely for people visiting the proposed community purpose use. In discussion with Shire officers, the requirement to provide an ACROD parking bay on-site was noted.

5.4 Landscaping

It is proposed that the yard at the rear of the building be landscaped with lawn, a fire pit, and vegetable patches as an extension of the community uses. The existing large tree will be retained. A small shed for the storage of gardening equipment is proposed towards the rear boundary.

By maximising the amount of garden area, the microclimate of the rear yard will be improved and natural absorption of rainfall will be possible.

5.5 Servicing

5.5.1 Wastewater

The old septic tank/leach drain system will be decommissioned and the building connected to the sewerage system.

5.5.2 Electricity

All electrical wiring and communications will be upgraded to meet current standards.

5.5.3 Stormwater

Stormwater and drainage will meet the Shire's requirements. Rainwater tanks are proposed to capture roof run-off. Rain falling on the garden areas will be absorbed by the garden soil.

5.5.4 Bin Stores

Bins will be stored near the garden shed, where they will be easy to access and wheel to the front of the building on collection day.

6. Conclusions

The proposed community purposes use will facilitate the conservation of a significant building within the Central York Heritage Precinct. Along with the former Oddfellows Hall, the Town Hall,

and the Imperial Hotel, the building is the only remaining original building representing Joaquina Street's diverse and colourful history.

The proposal is to restore the original face brick façade and adapt the long-neglected building for use as a beautiful, multi-purpose community space that can be hired out by groups and clubs at affordable rates. The rear of the building will become a garden area.

The streetscape of Joaquina Street and the wider heritage precinct will be vastly improved by the proposed conservation works, and the community use will activate the street by increasing pedestrian numbers. Improvements to the building will be sensitively undertaken and the minor interventions to improve the comfort for occupants, such as a new front door and additional side windows, will have minimal impact on the building's heritage values or those of the wider precinct, and can be supported.

The activities and the hours of operation will not result in adverse impacts such as noise or parking congestion in the neighbourhood. The busiest times will be early morning and evening, outside standard business hours when demand for on-street and public parking is typically highest.

The use is permissible in the zone and is compatible with the heritage of the building which seems to have been the focus of many community events in its early years. The development is consistent with the objectives of the Regional Centre zone, and approval of the proposal is respectfully sought.



AUSTRALIAN STANDARDS

THIS DEVELOPEMENT TO COMPLY WITH THE FOLLOWING STANDARDS : -

1. SOIL CONDITIONS IN ACCORDANCE TO AS 2870
2. METAL SHEET CLADDING TO AS 1562.1
3. CONCRETE CODE AS 2870 AND 3600
4. STRUCTURAL STEEL CODE AS 3678
5. EARTHQUAKE DESIGN CODE AS 1170.4
6. LIGHT TIMBER FRAMING CODE AS 1684.2 - 2010
7. GLAZING AND WINDOWS TO AS 2047 AND AS1288
8. SMOKE ALARMS BATTERIES TO AS 3786
9. WET AREAS TO BCA PART 3.8.1 AND AS 3740

GENERAL NOTES

1. ALL DIMENSIONS, LEVELS & MATERIALS TO BE CHECKED BY BUILDER PRIOR TO WORK COMMENCING.
2. ALL CONSTRUCTION TO CONFORM TO LOCAL AUTHORITIES BYLAWS AND THE BUILDING CODE OF AUSTRALIA
3. ALL FINISHES TO BE AS SELECTED BY OWNER.
4. THIS DRAWING TO BE READ IN CONJUNCTION WITH ALL OTHERS IN THE SET.
5. ENGINEERS DETAILS ARE TO TAKE PRECEDENCE OVER ARCHITECTURAL DETAILS
6. AN APPROVED METHOD OF TERMITE PROTECTION (BIFENTHRIN OR SIMILAR) TO BE USED BELOW ALL NEW CONCRETE.

DRAWING LIST

1. GENERAL NOTES
2. SITE PLAN
3. PROPOSED FLOOR PLAN
4. ELEVATIONS 1 AND 2
5. ELEVATIONS 3 AND 4
6. SECTION AT A - A
7. CONCRETE DETAILS
8. PLUMBING PLAN
9. ELECTRICAL PLAN
10. CONCRETE FLOOR

DESIGN CRITERIA

1. REGION A. TERRAIN CATAGORY 2 TO AS 1170.2
2. 'M' CLASS SITE TO AS 2070. NATURAL GROUND TO BE COMPACTED TO 92% MMDD LEVEL WITH SAND PAD IF NECESSARY. DO NOT CUT TO FILL UNDER BUILDINGS
3. ACCELERATION COEFFICIENT OF 0.13 TO AS 1170.4 TO EARTHQUAKE CODE



5th Sept. 2022

		PINEFIELD'S OF YORK		RENOVATIONS		GENERAL NOTES	
				CLIENT : J. and R. MARWICK 7 JOAQUINA STREET YORK WA 6302		NORTH DRAWN GMB SCALE	
		GARY W. BYFIELD PO BOX 326 YORK W.A. 6302 MOBILE 0414 885 338 EMAIL gwb151@gmail.com				DATE JUN 22 REVISION A	
ISSUED FOR REVIEW						JOB No 30-21/22	
REVISION						SHEET 01 A3	

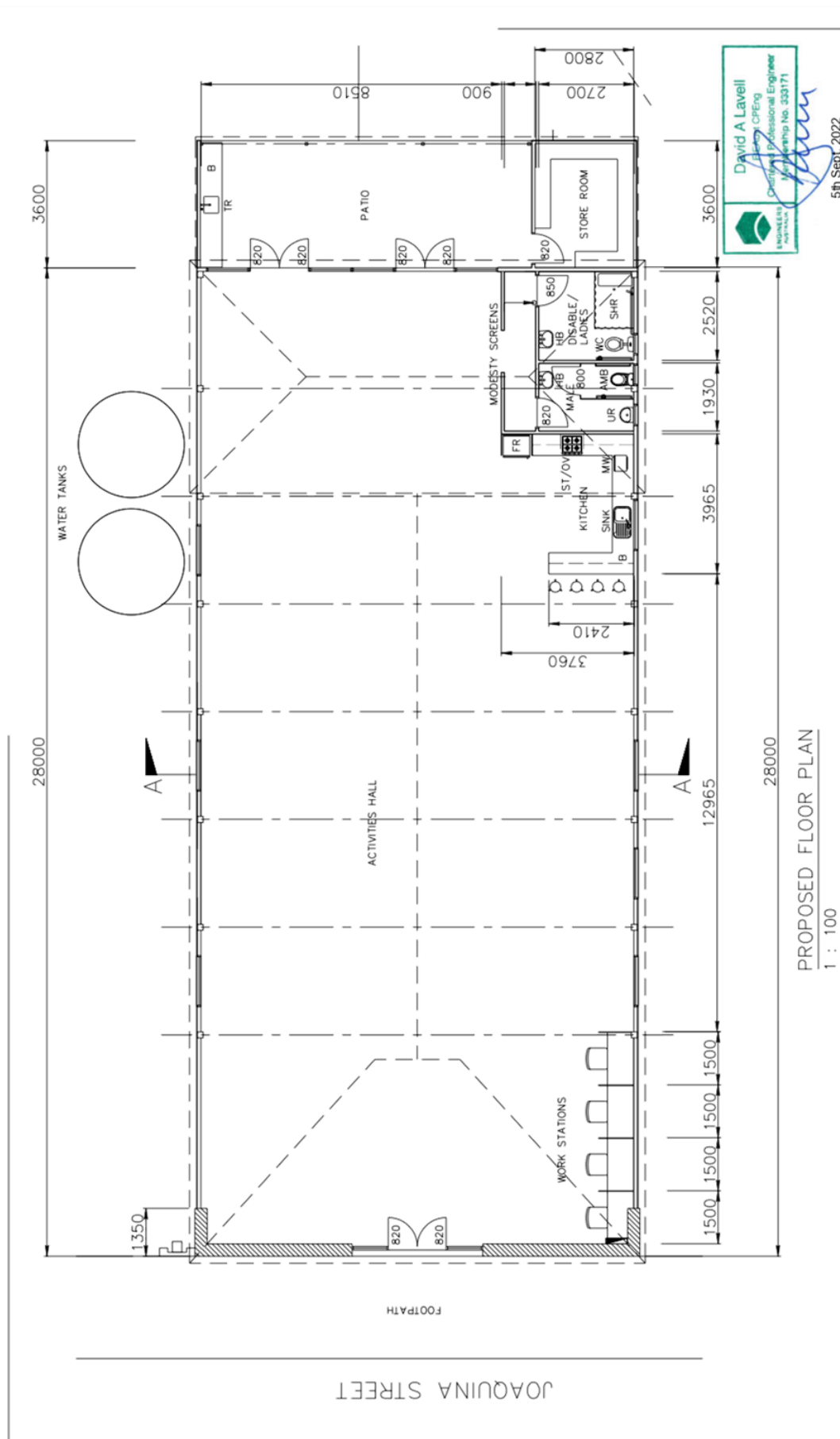

PROPOSED FLOOR PLAN
1 : 100

ISSUED FOR REVIEW		DATE	
A			
REVISION			

		PINEFIELD'S OF YORK RENOVATIONS	
GARY W. BYFIELD PO BOX 326 YORK W.A. 6302 MOBILE 0414 885 338 EMAIL gwb151@gmail.com		CLIENT : J. and R. MARWICK 7 JOAQUINA STREET YORK WA 6302	
NORTH			
DRAWN	GWB	SCALE	1 : 50
DATE	JUN 22	REVISION	A
JOB No	30-21/22	SHEET	03 A3

David A Lavell
 Certified Professional Engineer
 Mechanical
 Membership No. 33171
 5th Sept. 2022

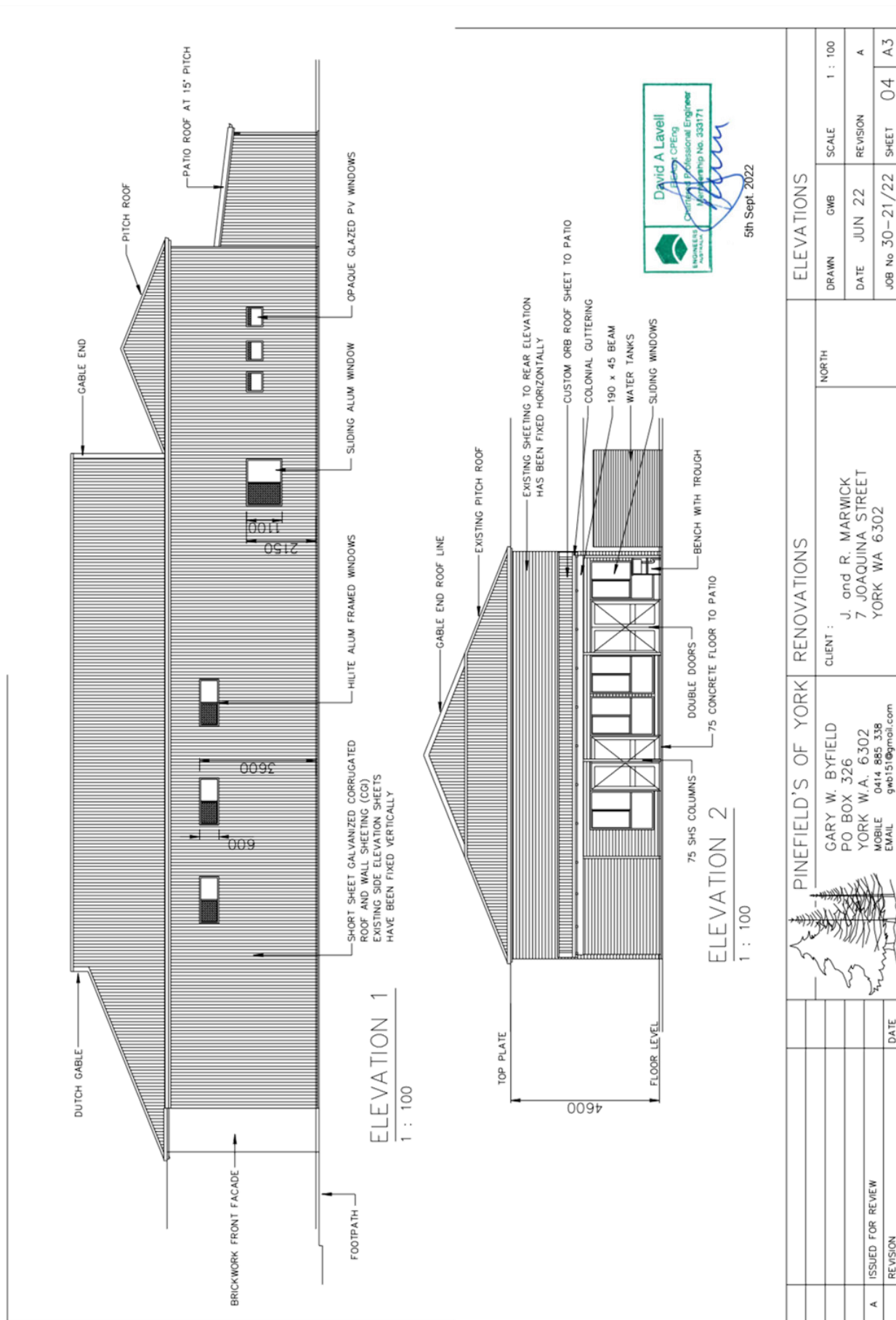

PINEFIELD'S OF YORK RENOVATIONS		ELEVATIONS	
CLIENT : GARY W. BYFIELD PO BOX 326 YORK W.A. 6302 MOBILE 0414 885 338 EMAIL gwb151@gmail.com		DRAWN GMB SCALE 1 : 100	
J. and R. MARWICK 7 JOAQUINA STREET YORK WA 6302		DATE JUN 22 REVISION A	
NORTH		JOB No 30-21/22 SHEET 04 A3	
ISSUED FOR REVIEW	DATE		
REVISION	DATE		

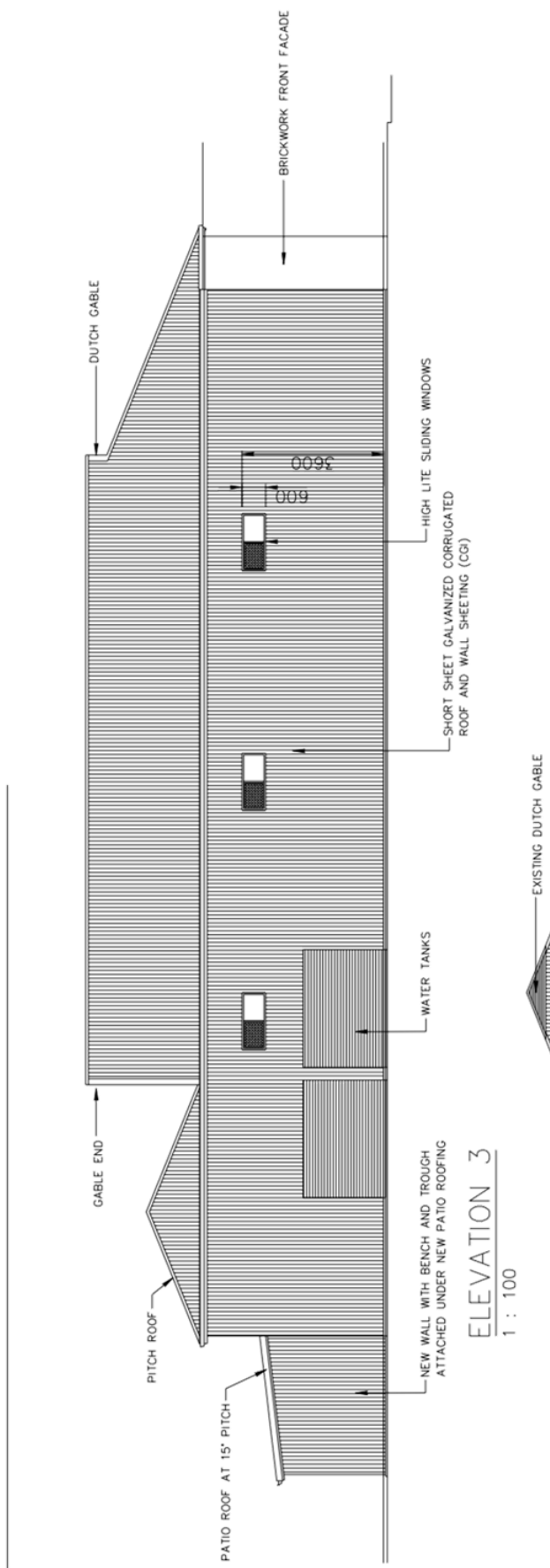

ELEVATION 3
1 : 100

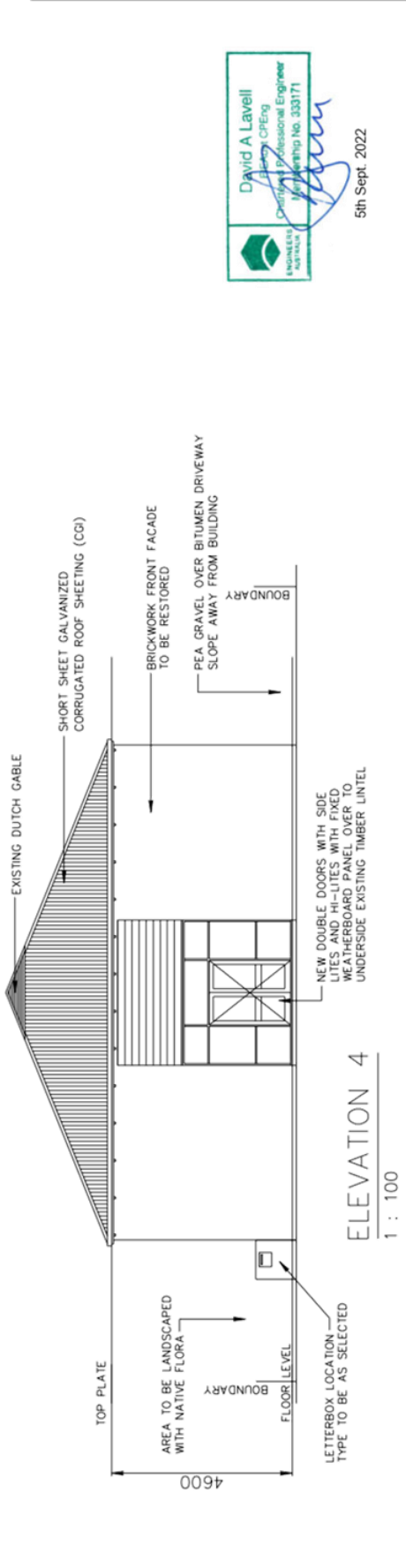

ELEVATION 4
1 : 100

David A Lavell
 Chartered Professional Engineer
 License No. 333171
 5th Sept. 2022

ELEVATIONS		RENOVATIONS		ELEVATIONS	
DRAWN	GWB	SCALE	1 : 100		
DATE	JUN 22	REVISION	A		
JOB No	30-21/22	SHEET	05		A3
NORTH		CLIENT :		PINEFIELD'S OF YORK	
		J. and R. MARWICK		GARY W. BYFIELD	
		7 JOAQUINA STREET		PO BOX 326	
		YORK WA 6302		YORK W.A. 6302	
				MOBILE 0414 885 338	
				EMAIL gwb151@gmail.com	
ISSUED FOR REVIEW	DATE				
REVISION					

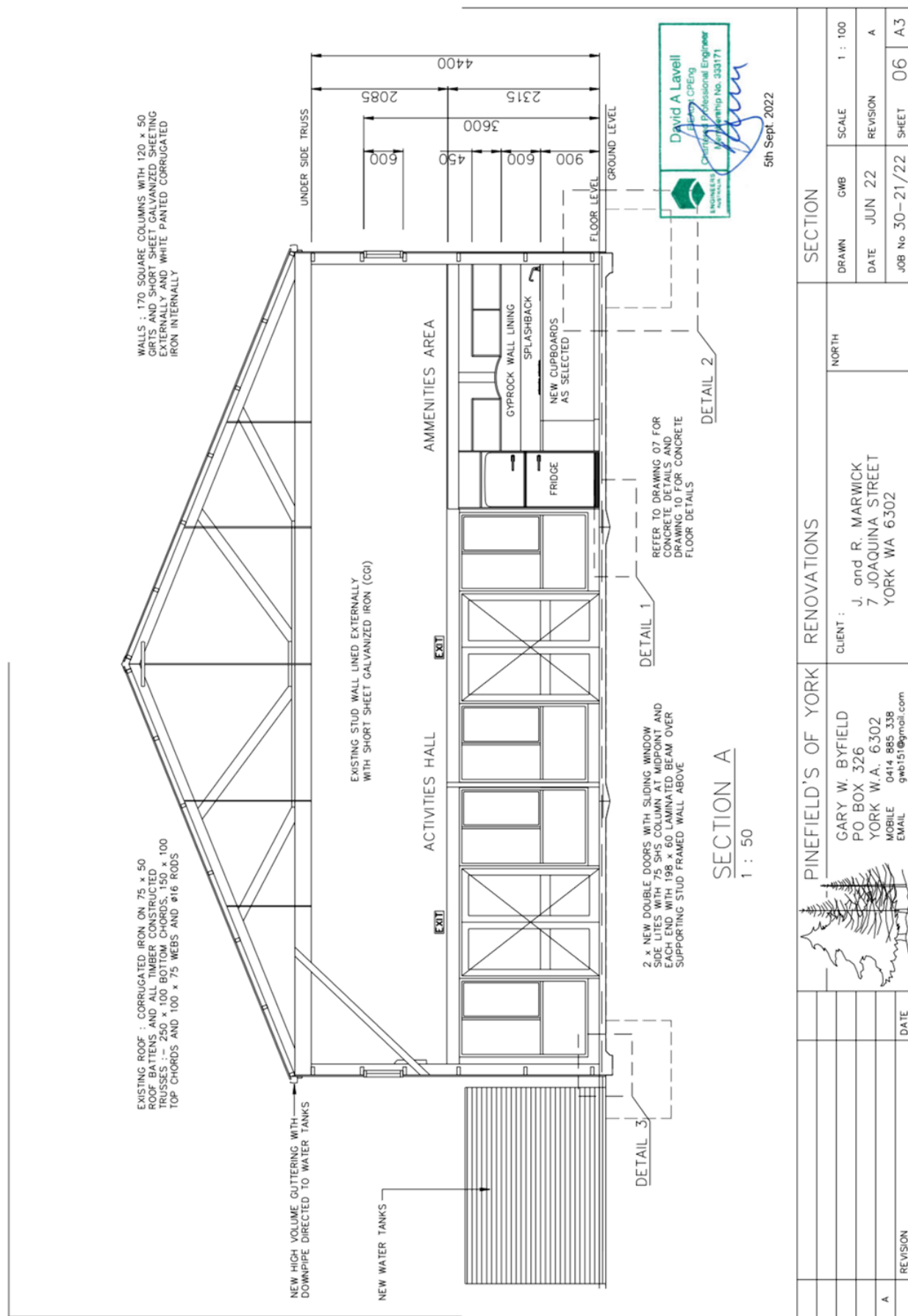

SECTION		SECTION	
DRAWN	GWB	SCALE	1 : 100
DATE	JUN 22	REVISION	A
JOB No	30-21/22	SHEET	06
PINEFIELD'S OF YORK		RENOVATIONS	
GARY W. BYFIELD PO BOX 326 YORK W.A. 6302 MOBILE 0414 885 338 EMAIL gwb151@gmail.com		CLIENT : J. and R. MARWICK 7 JOAQUINA STREET YORK WA 6302	
NORTH 			
A	REVISION	DATE	

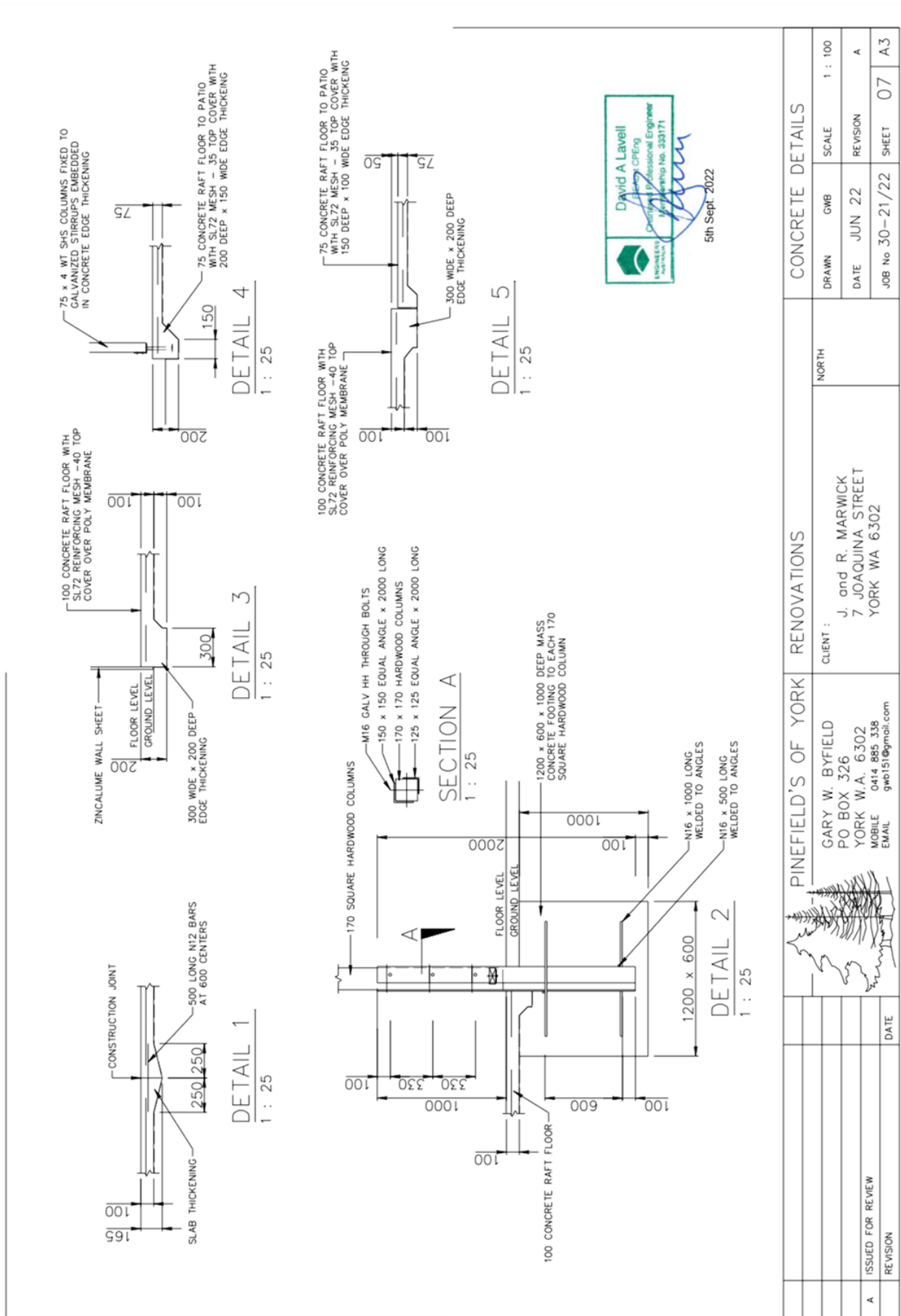

David A Lavell
 Chartered Professional Engineer
 Registration No. 333171
 5th Sept. 2022

PINEFIELD'S OF YORK		RENOVATIONS		CONCRETE DETAILS	
GARY W. BYFIELD PO BOX 326 YORK W.A. 6302 MOBILE 0414 885 338 EMAIL gwb15@gmail.com		CLIENT : J. and R. MARWICK 7 JOAQUINA STREET YORK WA 6302		NORTH	
ISSUED FOR REVIEW	DATE	DRAWN	GWB	SCALE	1 : 100
REVISION		DATE	JUN 22	REVISION	A
		JOB No	30-21/22	SHEET	07 A3

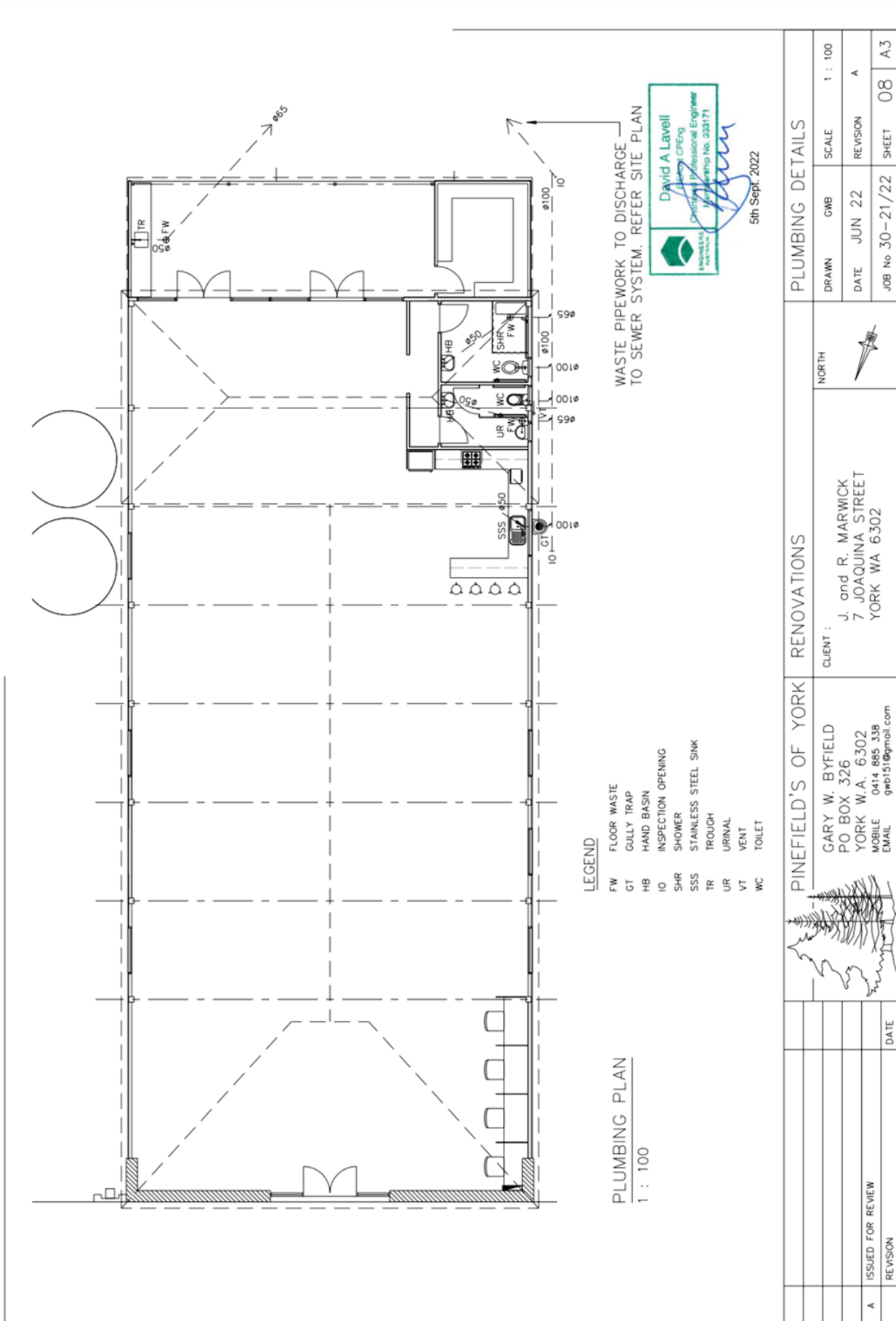

PLUMBING DETAILS			
DRAWN	CMB	SCALE	1 : 100
DATE	JUN 22	REVISION	A
JOB No	30-21/22	SHEET	08
			A3

NORTH

CLIENT :
J. and R. MARWICK
7 JOAQUINA STREET
YORK WA 6302

PINEFIELD'S OF YORK

GARY W. BYFIELD
PO BOX 326
YORK W.A. 6302
MOBILE 0414 885 338
EMAIL gwb151@gmail.com

ISSUED FOR REVIEW	DATE
A	
REVISION	

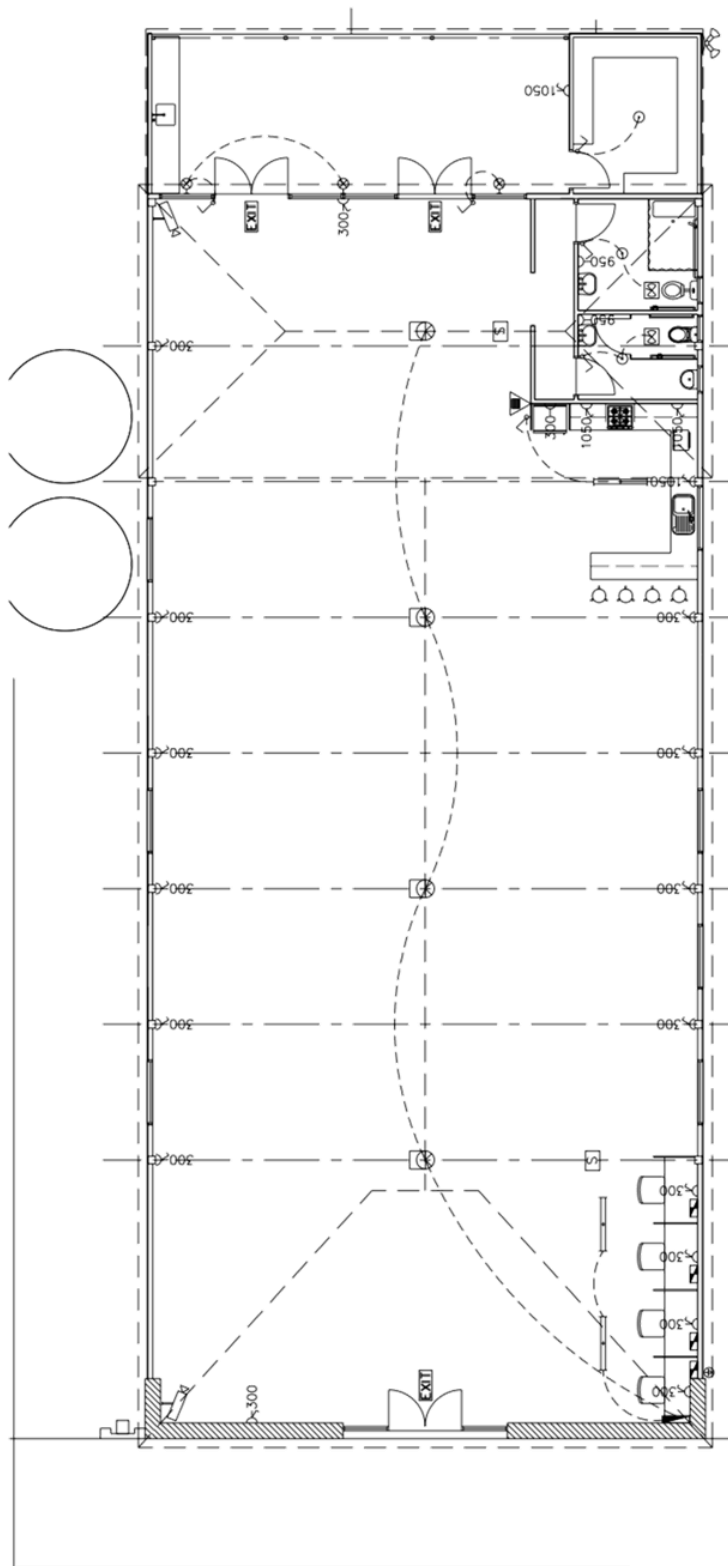

- LEGEND**
- ⊕ DISTRIBUTION BOARD
 - ⊕ BUILDING EARTH STAKE
 - ⊕ FLOURESCENT LIGHT FITTING
 - ⊕ CEILING MOUNTED LIGHT FITTING
 - ⊕ WALL MOUNTED LIGHT
 - ⊕ HIGHBAY MOUNTED DOWNLIGHT
 - ⊕ ILLUMINATED EXIT SIGN
 - ⊕ LIGHT SWITCH AT 1200
 - ⊕ EXHAUST FAN VENTED TO FRESH AIR
- 300 10A MULTIPLE GPO HEIGHT ABOVE FFL
 10A SINGLE GPO HEIGHT ABOVE FFL
 COMMUNICATIONS AND IT SUPPORT
 SECURITY CAMERA LOCATION
 SECURITY YARD LIGHT
 FIRE EXTINGUISHER LOCATION
 HARD WIRED SMOKE DETECTOR

ELECTRICAL PLAN
1 : 100

PINEFIELD'S OF YORK		RENOVATIONS		ELECTRICAL DETAILS	
GARY W. BYFIELD PO BOX 326 YORK W.A. 6302 MOBILE 0414.885.338 EMAIL gwb151@gmail.com		CLIENT : J and R. MARWICK 7 JOAQUINA STREET YORK WA 6302		DRAWN GWB DATE JUN 22 JOB No 30-21/22	SCALE 1 : 100 REVISION A SHEET 09 A3
		NORTH 			
REVISION	DATE				
A					

cdp | Proposed Community Centre - 7 (Lot 6) Joaquina Street, York



Appendices.

Appendix 1 Certificate of Title

cdp | Proposed Community Centre - 7 (Lot 6) Joaquina Street, York

WESTERN



AUSTRALIA

REGISTER NUMBER	
6/P63	
DUPLICATE EDITION	DATE DUPLICATE ISSUED
1	10/5/2007

RECORD OF CERTIFICATE OF TITLE
UNDER THE TRANSFER OF LAND ACT 1893

VOLUME 1857 FOLIO 293

The person described in the first schedule is the registered proprietor of an estate in fee simple in the land described below subject to the reservations, conditions and depth limit contained in the original grant (if a grant issued) and to the limitations, interests, encumbrances and notifications shown in the second schedule.

BGRoberts
REGISTRAR OF TITLES

**LAND DESCRIPTION:**

LOT 6 ON PLAN 63

REGISTERED PROPRIETOR:
(FIRST SCHEDULE)

REBECCA MAREE MARWICK
JUSTIN JAMES MARWICK
BOTH OF 67 PANMURE ROAD YORK WA 6302
AS JOINT TENANTS

(T P230338) REGISTERED 27/7/2022

LIMITATIONS, INTERESTS, ENCUMBRANCES AND NOTIFICATIONS:
(SECOND SCHEDULE)

Warning: A current search of the sketch of the land should be obtained where detail of position, dimensions or area of the lot is required.
* Any entries preceded by an asterisk may not appear on the current edition of the duplicate certificate of title.
Lot as described in the land description may be a lot or location.

-----END OF CERTIFICATE OF TITLE-----

STATEMENTS:

The statements set out below are not intended to be nor should they be relied on as substitutes for inspection of the land and the relevant documents or for local government, legal, surveying or other professional advice.

SKETCH OF LAND: 1857-293 (6/P63)
PREVIOUS TITLE: 1185-270
PROPERTY STREET ADDRESS: 7 JOAQUINA ST, YORK.
LOCAL GOVERNMENT AUTHORITY: SHIRE OF YORK

NOTE 1: DUPLICATE CERTIFICATE OF TITLE NOT ISSUED AS REQUESTED BY DEALING P230338

LANDGATE COPY OF ORIGINAL NOT TO SCALE 27/07/2022 11:54 AM Request number: 63913135

Landgate
www.landgate.wa.gov.au

Appendix 2

Heritage Place Data Sheet

SHIRE OF YORK Local Heritage Survey 2019
PLACE No. 129 - WAREHOUSE
7 Joaquina Street
CENTRAL YORK HERITAGE AREA
HERITAGE AREA GRADE B: High level of cultural heritage significance to Shire of York 'Heritage List.' TPS: Development Application. Retain & conserve.
CONTRIBUTION to AREA: Some



Place name	WAREHOUSE		
Address	7 Joaquina Street		
Town/Region	YORK		
Lot No.	6	Plan:	63
		Certificate of Title:	1857/293
STATEMENT OF SIGNIFICANCE			
The warehouse, 7 Joaquina Street is significant in representing the diversity of development in York, located in close proximity to the railway station and the main commercial street, it is a rare remaining building of its type within the central York area, and makes a contribution to the history and the historic townscape.			
HERITAGE AREA GRADE B: Shire of York 'Heritage List' TPS: Development Application. Retain & conserve.			
CONSTRUCTION DATE	c.1920 (may be earlier as evidenced by the brickwork)		
Uses	Warehouse		
CONSTRUCTION MATERIALS:	Timber framed with a masonry frontage		
Walls	Painted face brick frontage with vertical corrugated iron sides & rear walls.		
Roof	Hipped roof with a vented front gablet		
Other			
ARCHITECTURAL STYLE:	Interwar functional (may be Federation or earlier as evidenced by the brickwork)		
DESCRIPTION:			
The single storey building has a double vehicular entry central on the zero-lot-lined frontage. The face brick work on the front of the warehouse has been painted. It evidences a Garden wall brick bond, also known as Colonial bond. Usually it was a preferred bonding pre-Federation as it was used mostly in single leaf brick construction. It is recognised by 3 or 4 courses of stretcher bond bricks to one course of header bricks, as evidenced on the front of the warehouse.			
CONDITION:	Fair	INTEGRITY:	Low/Moderate degree
		AUTHENTICITY:	Moderate/high degree
HISTORICAL NOTES			
No evidence revealed in searches of The York Society archives.			
LISTINGS			
Nil			

SHIRE OF YORK Local Heritage Survey 2019**PLACE No. 129 - WAREHOUSE****7 Joaquina Street****CENTRAL YORK HERITAGE AREA****HERITAGE AREA GRADE B:** High level of cultural heritage significance to Shire of York 'Heritage List.' TPS: Development Application. Retain & conserve.**CONTRIBUTION to AREA:** Some**SUPPORTING INFORMATION/BIBLIOGRAPHY**

The York Society archives



Town Planning & Urban Design

- p. 08 6333 1888
 - e. info@cdpaus.com.au
 - a. 2/464 Murray St,
Perth WA 6000
PO Box 8002
Cloisters Square 6850
- cdpaus.com.au

AUSTRALIAN STANDARDS

THIS DEVELOPEMENT TO COMPLY WITH THE FOLLOWING STANDARDS :-

1. SOIL CONDITIONS IN ACCORDANCE TO AS 2870
2. METAL SHEET CLADDING TO AS 1562.1
3. CONCRETE CODE AS 2870 AND 3600
4. STRUCTURAL STEEL CODE AS 3678
5. EARTHQUAKE DESIGN CODE AS 1170.4
6. LIGHT TIMBER FRAMING CODE AS 1684.2 – 2010
7. GLAZING AND WINDOWS TO AS 2047 AND AS1288
8. SMOKE ALARMS BATTERIES TO AS 3786
9. WET AREAS TO BCA PART 3.8.1 AND AS 3740

DRAWING LIST

1. GENERAL NOTES
2. SITE PLAN
3. PROPOSED FLOOR PLAN
4. ELEVATIONS 1 AND 2
5. ELEVATIONS 3 AND 4
6. SECTION AT A – A
7. CONCRETE DETAILS
8. PLUMBING PLAN
- 9 ELECTRICAL PLAN
10. CONCRETE FLOOR



5th Sept. 2022

GENERAL NOTES

1. ALL DIMENSIONS, LEVELS & MATERIALS TO BE CHECKED BY BUILDER PRIOR TO WORK COMMENCING.
2. ALL CONSTRUCTION TO CONFORM TO LOCAL AUTHORITIES BYLAWS AND THE BUILDING CODE OF AUSTRALIA
3. ALL FINISHES TO BE AS SELECTED BY OWNER.
4. THIS DRAWING TO BE READ IN CONJUNCTION WITH ALL OTHERS IN THE SET.
5. ENGINEERS DETAILS ARE TO TAKE PRECEDENCE OVER ARCHITECTURAL DETAILS
- 6 AN APPROVED METHOD OF TERMITE PROTECTION (BIFENTHRIN OR SIMILAR) TO BE USED BELOW ALL NEW CONCRETE.

DESIGN CRITERIA

1. REGION A. TERRAIN CATAGORY 2 TO AS 1170.2
2. 'M' CLASS SITE TO AS 2070. NATURAL GROUND TO BE COMPACTED TO 92% MMDD LEVEL WITH SAND PAD IF NECESSARY. DO NOT CUT TO FILL UNDER BUILDINGS
3. ACCELERATION COEFFICIENT OF 0.13 TO AS 1170.4 TO EARTHQUAKE CODE

			 <p>PINEFIELD'S OF YORK</p> <p>GARY W. BYFIELD PO BOX 326 YORK W.A. 6302 MOBILE 0414 885 338 EMAIL gwb151@gmail.com</p>	RENOVATIONS	NORTH CLIENT : J. and R. MARWICK 7 JOAQUINA STREET YORK WA 6302	GENERAL NOTES				
							DRAWN	GWB	SCALE	
A	ISSUED FOR REVIEW						DATE	JUN 22	REVISION	A
	REVISION	DATE					JOB No	30-21/22	SHEET	01 A3

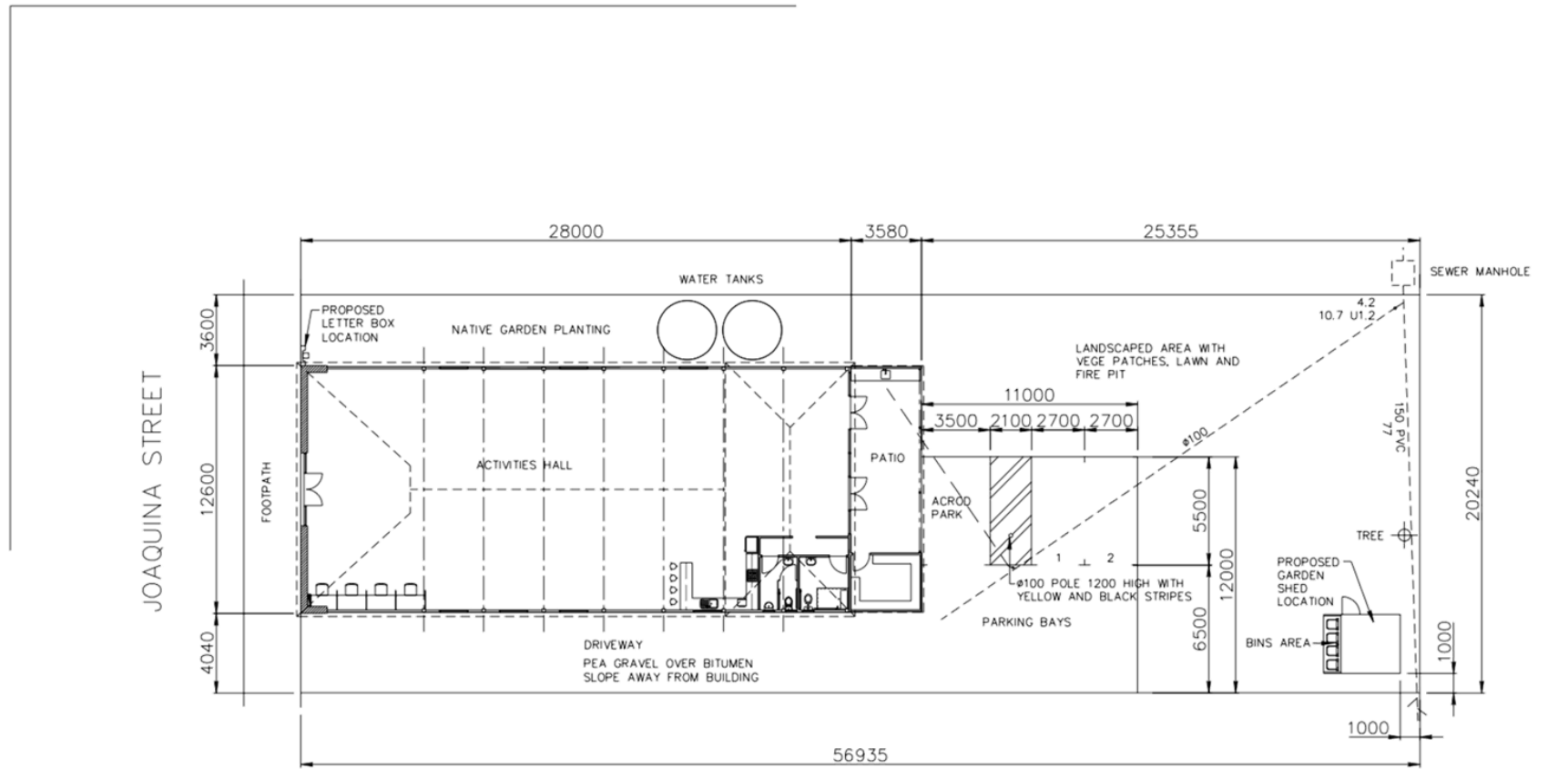

SITE PLAN
1 : 200

REFER TO DRAWING 08 FOR WASTE PIPEWORK AND PLUMBING LEGEND



5th Sept. 2022

			PINEFIELD'S OF YORK RENOVATIONS		NORTH 	SITE PLAN			
			GARY W. BYFIELD PO BOX 326 YORK W.A. 6302 MOBILE 0414 885 338 EMAIL gwb151@gmail.com			CLIENT : J. and R. MARWICK 7 JOAQUINA STREET YORK WA 6302		DRAWN GWB	SCALE 1 : 100
A	ISSUED FOR REVIEW					DATE JUN 22	REVISION A		
REVISION		DATE				JOB No 30-21/22	SHEET 02	A3	

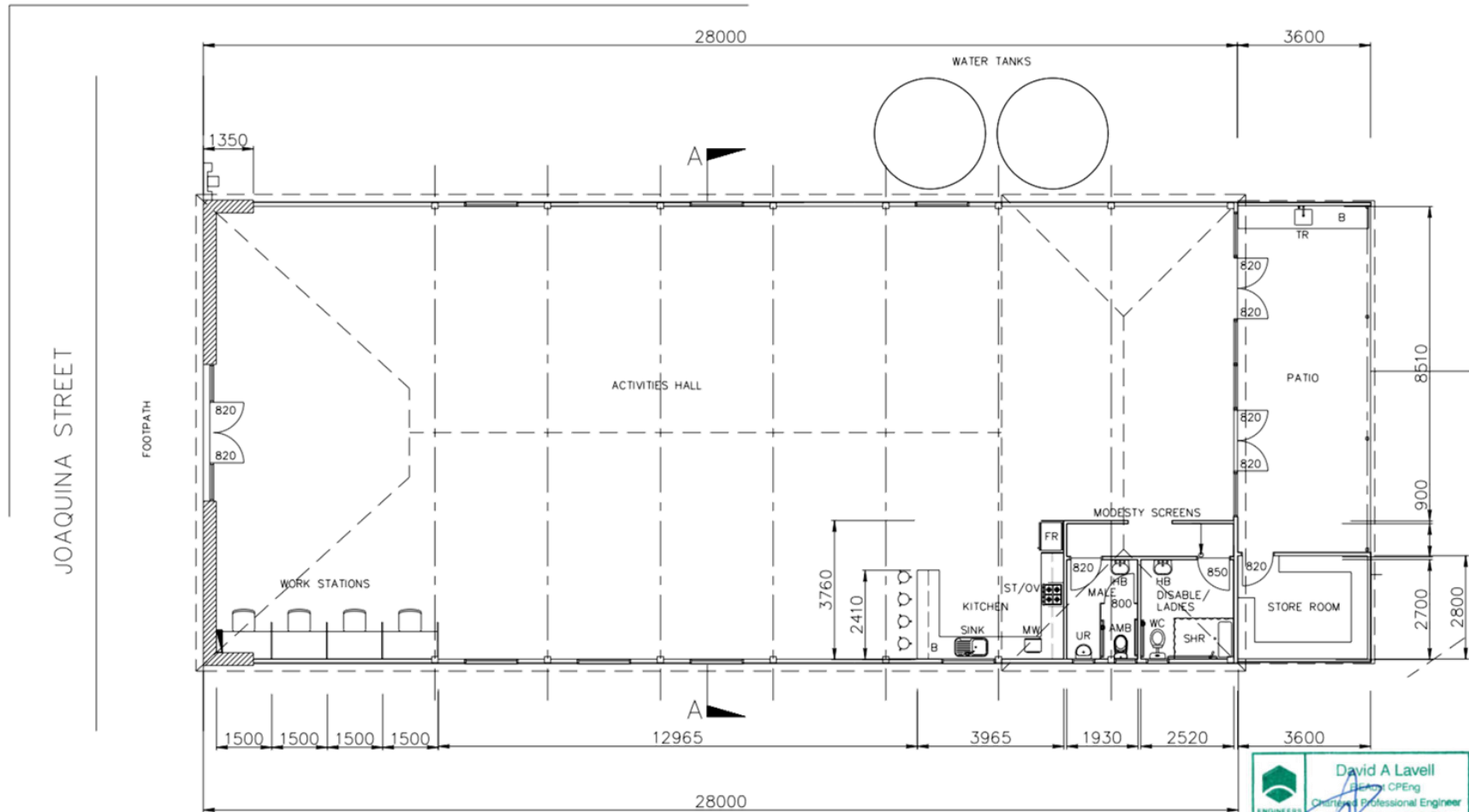

PROPOSED FLOOR PLAN
1 : 100



5th Sept. 2022

			PINEFIELD'S OF YORK RENOVATIONS		NORTH 	PROPOSED FLOOR PLAN		
			GARY W. BYFIELD PO BOX 326 YORK W.A. 6302 MOBILE 0414 885 338 EMAIL gwb151@gmail.com	CLIENT : J. and R. MARWICK 7 JOAQUINA STREET YORK WA 6302		DRAWN GWB	SCALE 1 : 50	
A	ISSUED FOR REVIEW					DATE JUN 22	REVISION A	
	REVISION	DATE				JOB No 30-21/22	SHEET 03	A3

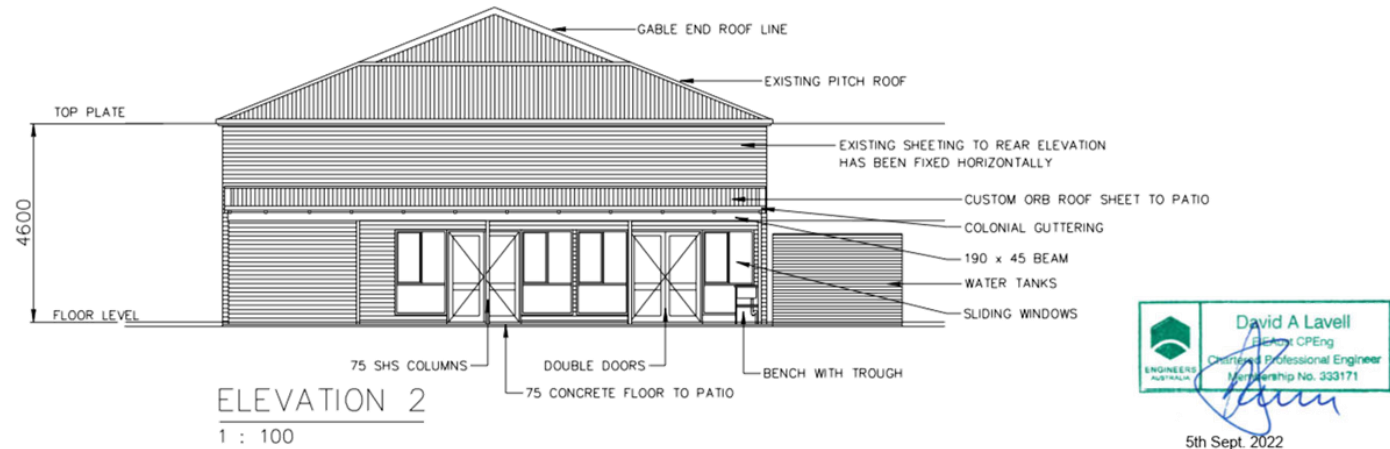
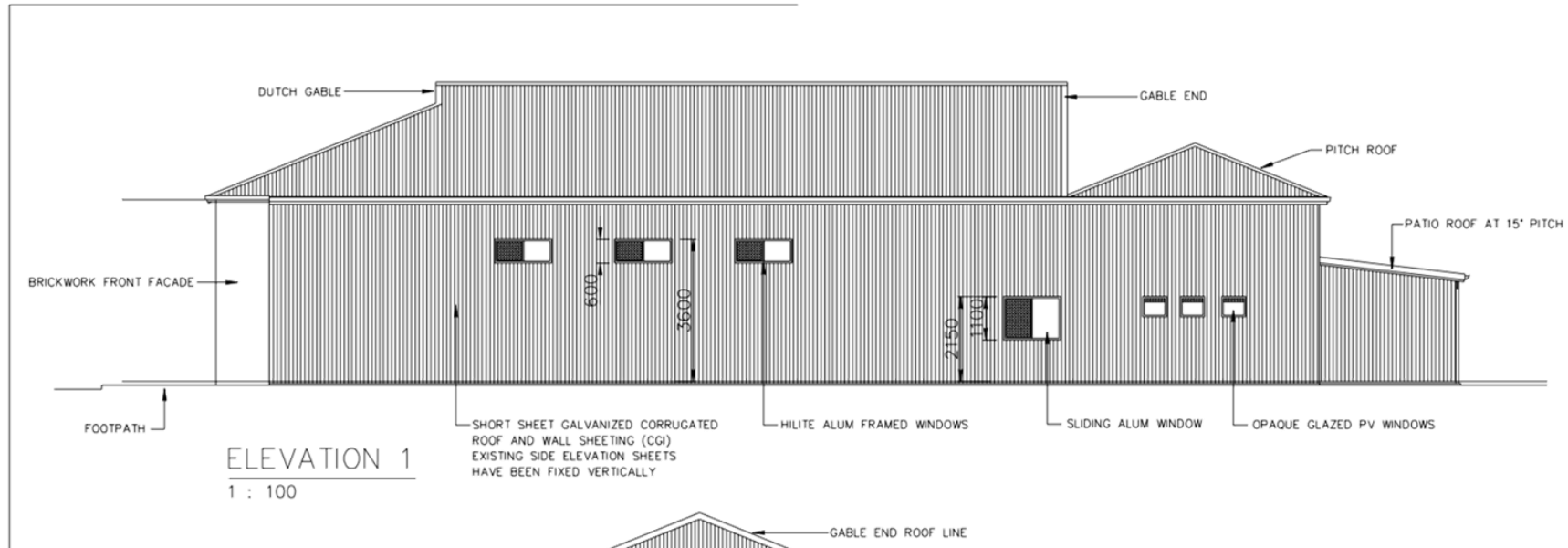

5th Sept. 2022

			<p>PINEFIELD'S OF YORK RENOVATIONS</p> <p>GARY W. BYFIELD PO BOX 326 YORK W.A. 6302 MOBILE 0414 885 338 EMAIL gwb151@gmail.com</p>	<p>CLIENT :</p> <p>J. and R. MARWICK 7 JOAQUINA STREET YORK WA 6302</p>	<p>NORTH</p>	ELEVATIONS		
						<p>DRAWN GWB SCALE 1 : 100</p> <p>DATE JUN 22 REVISION A</p> <p>JOB No 30-21/22 SHEET 04 A3</p>		
A	ISSUED FOR REVIEW							
	REVISION							

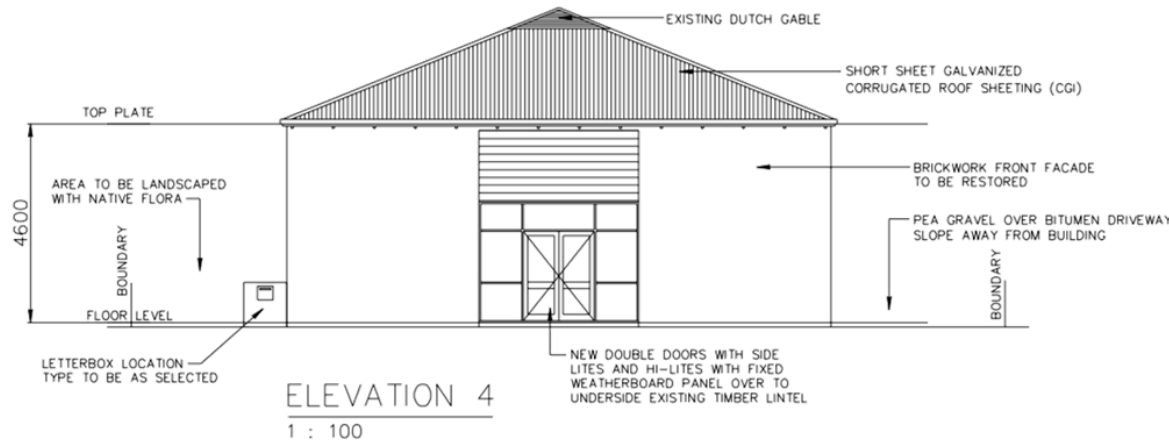
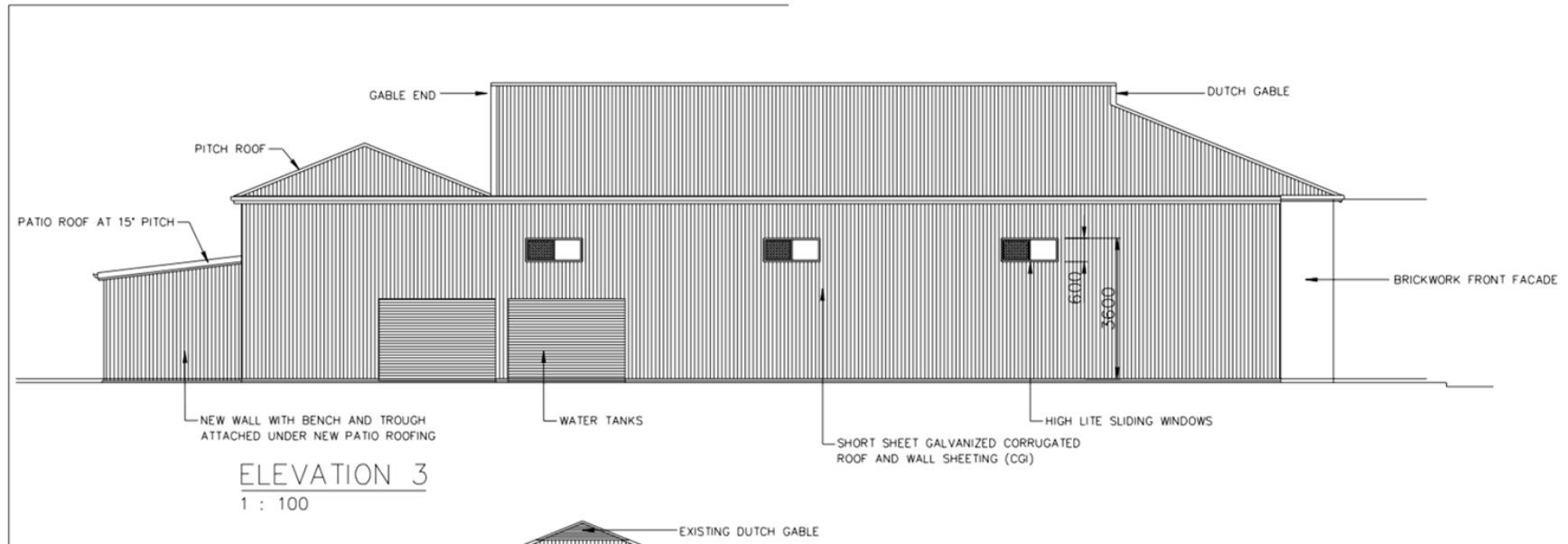

5th Sept. 2022

			<p>PINEFIELD'S OF YORK</p> <p>GARY W. BYFIELD PO BOX 326 YORK W.A. 6302 MOBILE 0414 885 338 EMAIL gwb151@gmail.com</p>	<p>CLIENT :</p> <p>J. and R. MARWICK 7 JOAQUINA STREET YORK WA 6302</p>	<p>NORTH</p>	ELEVATIONS			
						DRAWN	GWB	SCALE	1 : 100
A	ISSUED FOR REVIEW					DATE	JUN 22	REVISION	A
	REVISION	DATE				JOB No	30-21/22	SHEET	05 A3

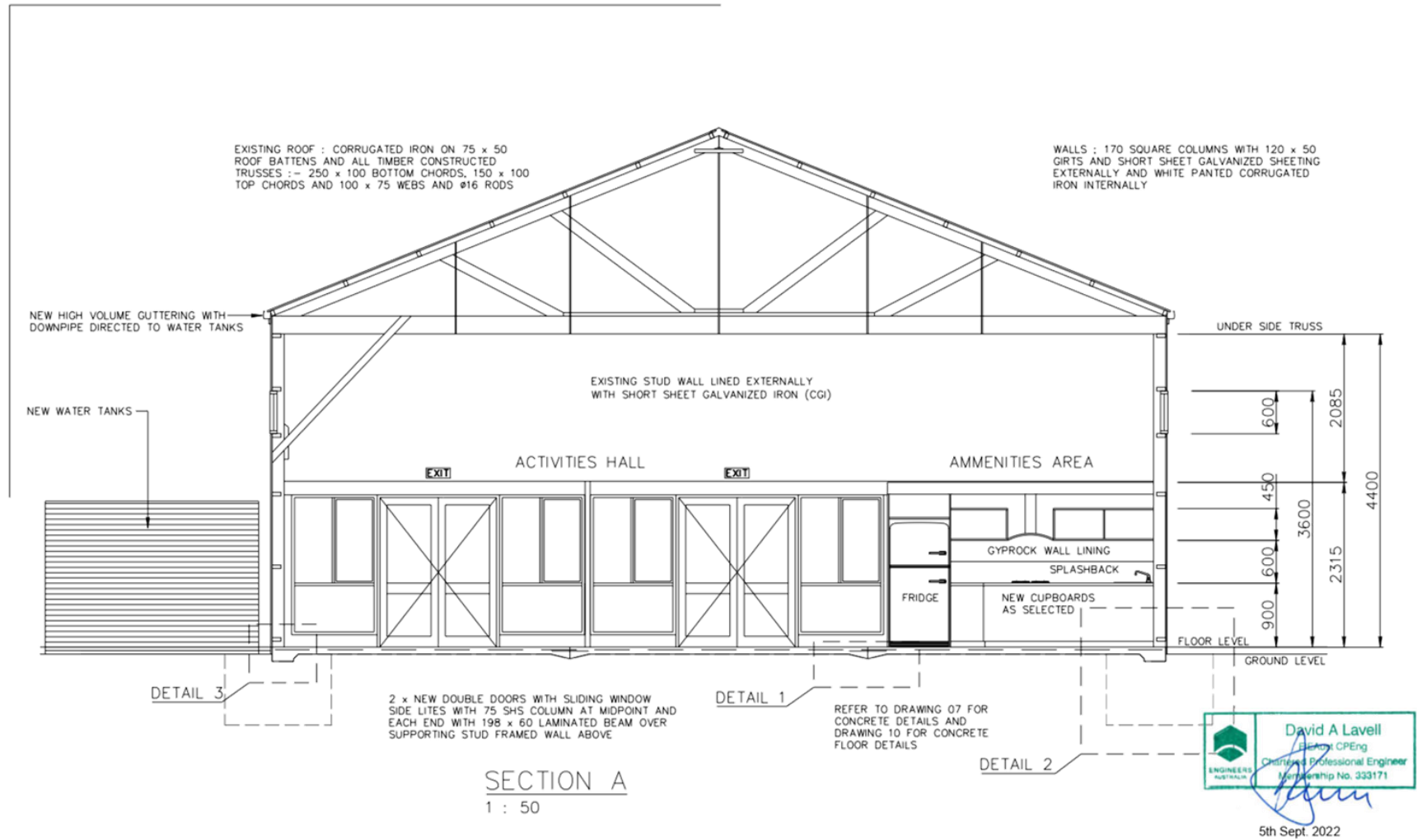

		<p>PINEFIELD'S OF YORK RENOVATIONS</p> <p>GARY W. BYFIELD PO BOX 326 YORK W.A. 6302 MOBILE 0414 885 338 EMAIL gwb151@gmail.com</p>	CLIENT :		NORTH	SECTION			
			J. and R. MARWICK 7 JOAQUINA STREET YORK WA 6302			DRAWN	GWB	SCALE	1 : 100
A						DATE	JUN 22	REVISION	A
REVISION			DATE			JOB No	30-21/22	SHEET	06 A3

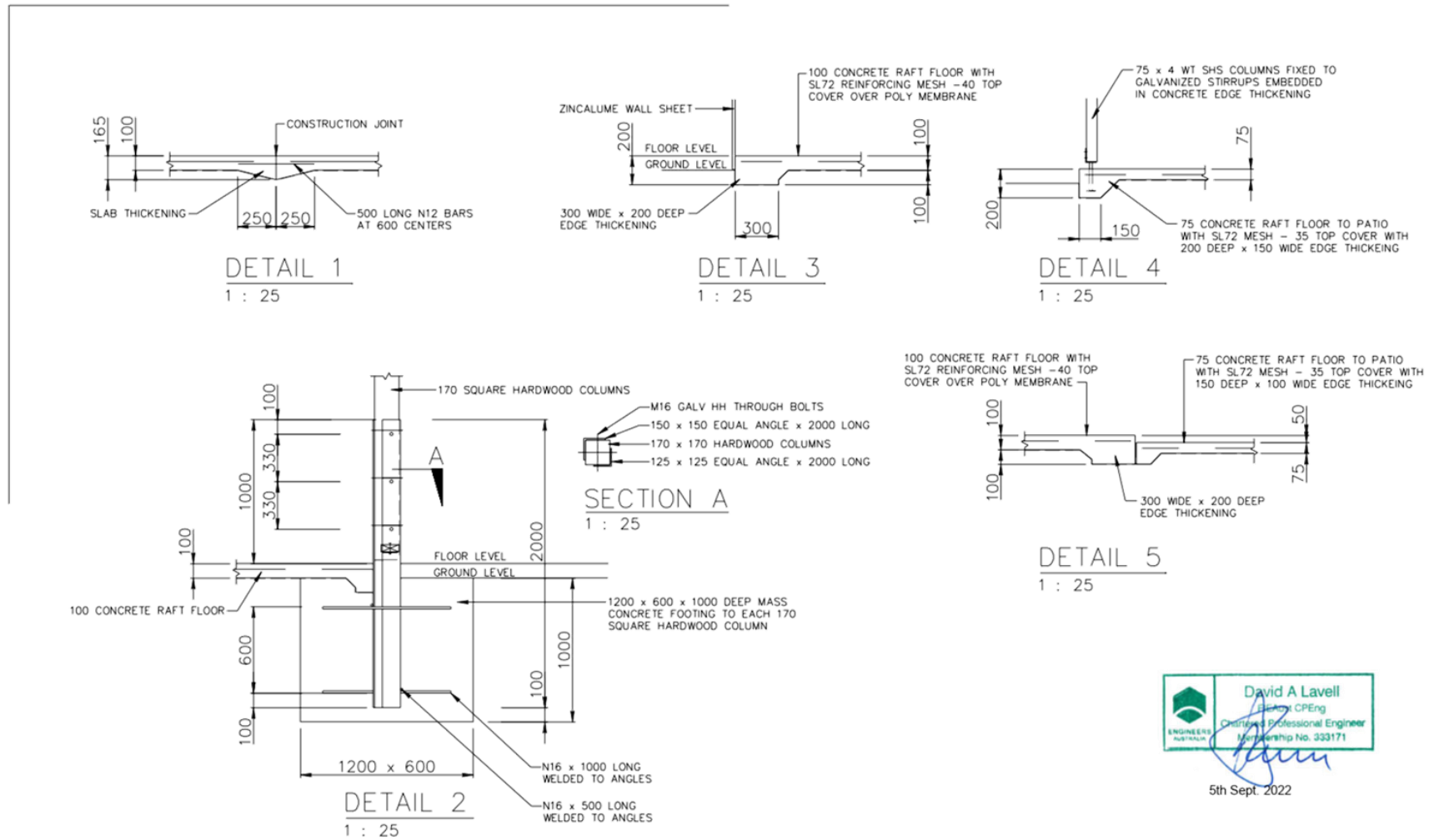

			PINEFIELD'S OF YORK RENOVATIONS		CONCRETE DETAILS	
			GARY W. BYFIELD PO BOX 326 YORK W.A. 6302 MOBILE 0414 885 338 EMAIL gwb151@gmail.com	CLIENT : J. and R. MARWICK 7 JOAQUINA STREET YORK WA 6302	NORTH	DRAWN GWB SCALE 1 : 100
A	ISSUED FOR REVIEW				DATE JUN 22	REVISION A
	REVISION	DATE			JOB No 30-21/22	SHEET 07 A3

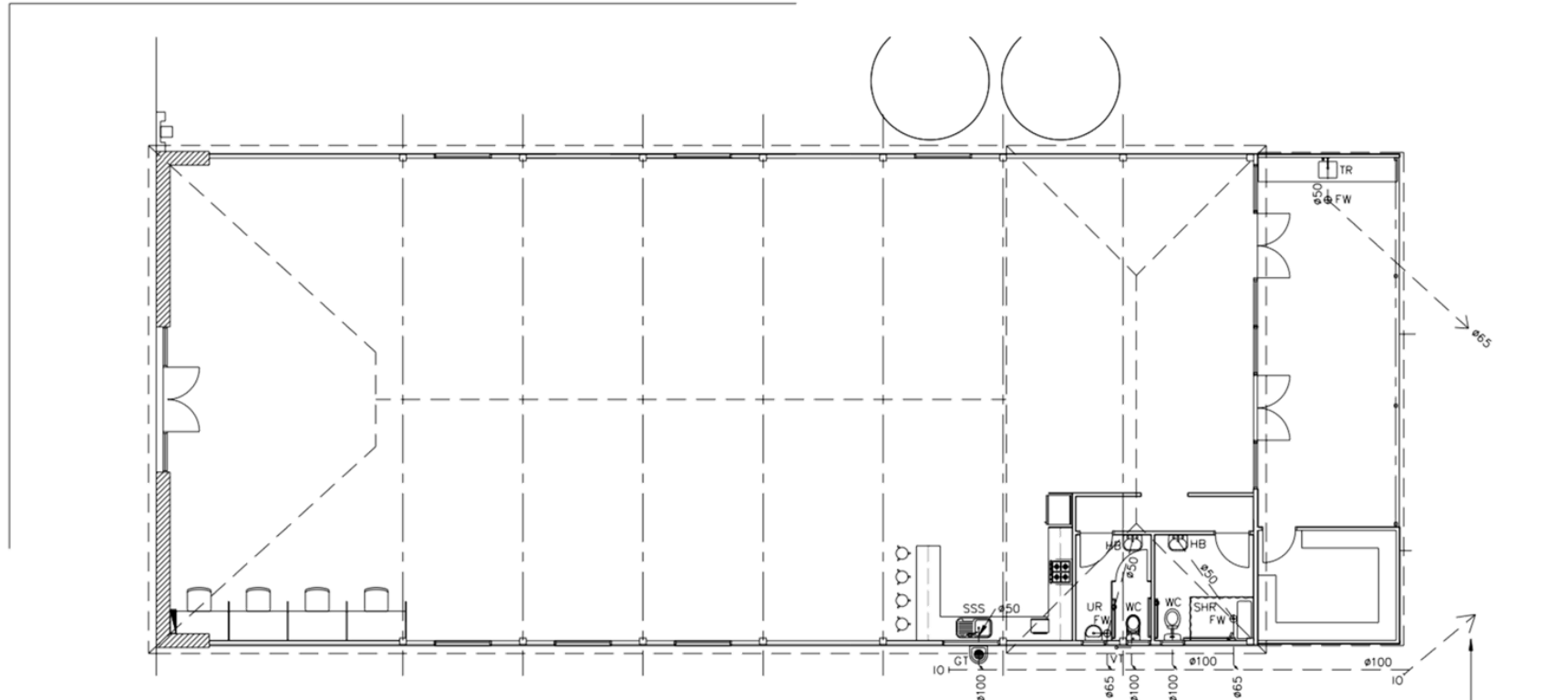

PLUMBING PLAN
1 : 100

LEGEND

- FW FLOOR WASTE
- GT GULLY TRAP
- HB HAND BASIN
- IO INSPECTION OPENING
- SHR SHOWER
- SSS STAINLESS STEEL SINK
- TR TROUGH
- UR URINAL
- VT VENT
- WC TOILET

WASTE PIPEWORK TO DISCHARGE TO SEWER SYSTEM. REFER SITE PLAN



5th Sept 2022

			PINEFIELD'S OF YORK RENOVATIONS		NORTH 	PLUMBING DETAILS	
			GARY W. BYFIELD PO BOX 326 YORK W.A. 6302 MOBILE 0414 885 338 EMAIL gwb151@gmail.com	CLIENT : J. and R. MARWICK 7 JOAQUINA STREET YORK WA 6302		DRAWN GWB DATE JUN 22 JOB No 30-21/22	SCALE 1 : 100 REVISION A SHEET 08 A3
A	ISSUED FOR REVIEW						
	REVISION						

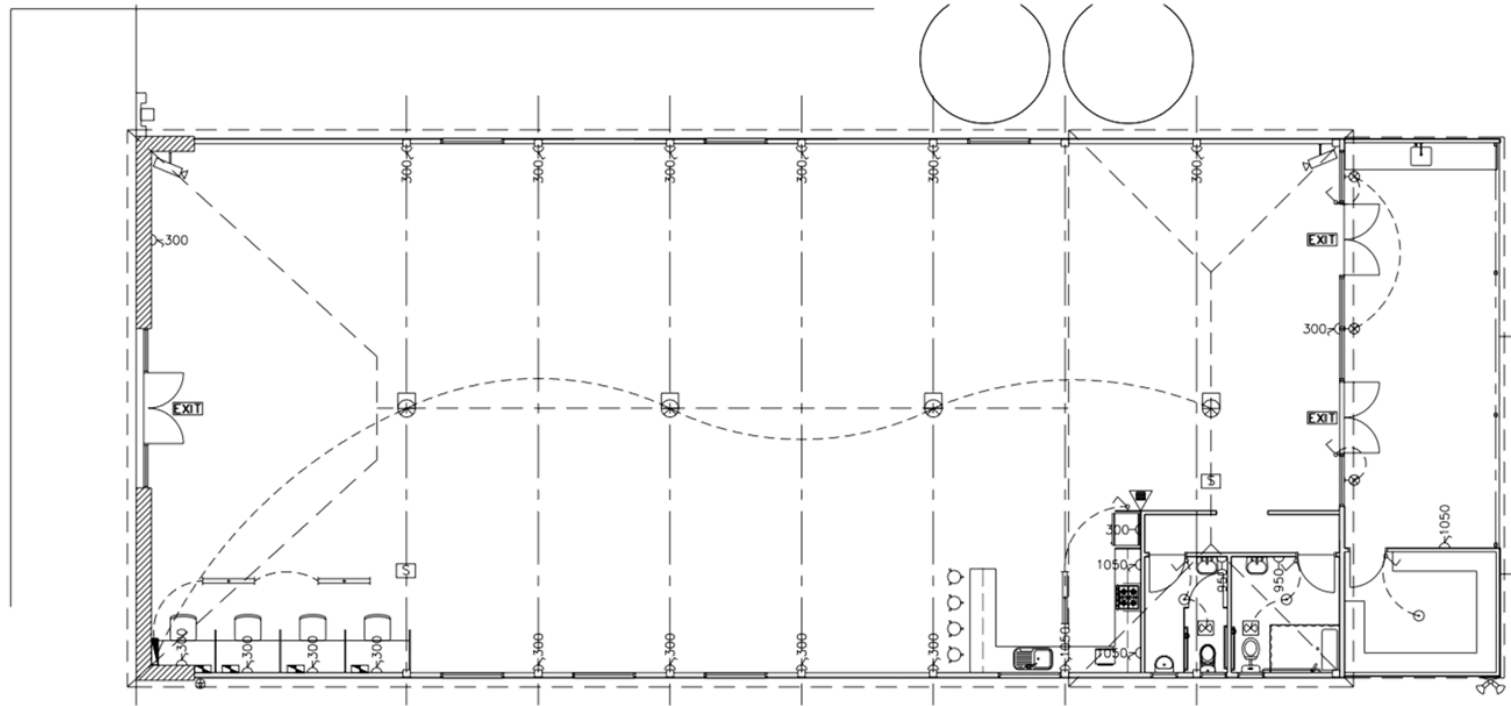

ELECTRICAL PLAN
1 : 100

LEGEND

- | | | | |
|--|---------------------------------|--|-----------------------------------|
| | DISTRIBUTION BOARD | | 10A MULTIPLE GPO HEIGHT ABOVE FFL |
| | BUILDING EARTH STAKE | | 10A SINGLE GPO HEIGHT ABOVE FFL |
| | FLOURESCENT LIGHT FITTING | | COMMUNICATIONS AND IT SUPPORT |
| | CEILING MOUNTED LIGHT FITTING | | SECURITY CAMERA LOCATION |
| | WALL MOUNTED LIGHT | | SECURITY YARD LIGHT |
| | HIGHBAY MOUNTED DOWNLIGHT | | FIRE EXTINGUISHER LOCATION |
| | ILLUMINATED EXIT SIGN | | HARD WIRED SMOKE DETECTOR |
| | LIGHT SWITCH AT 1200 | | |
| | EXHAUST FAN VENTED TO FRESH AIR | | |

		<p>PINEFIELD'S OF YORK GARY W. BYFIELD PO BOX 326 YORK W.A. 6302 MOBILE 0414 885 338 EMAIL gwb151@gmail.com</p>	RENOVATIONS		NORTH 	ELECTRICAL DETAILS				
			CLIENT :	J. and R. MARWICK 7 JOAQUINA STREET YORK WA 6302		DRAWN	GWB	SCALE	1 : 100	
A							DATE	JUN 22	REVISION	A
REVISION			DATE				JOB No	30-21/22	SHEET	09 A3

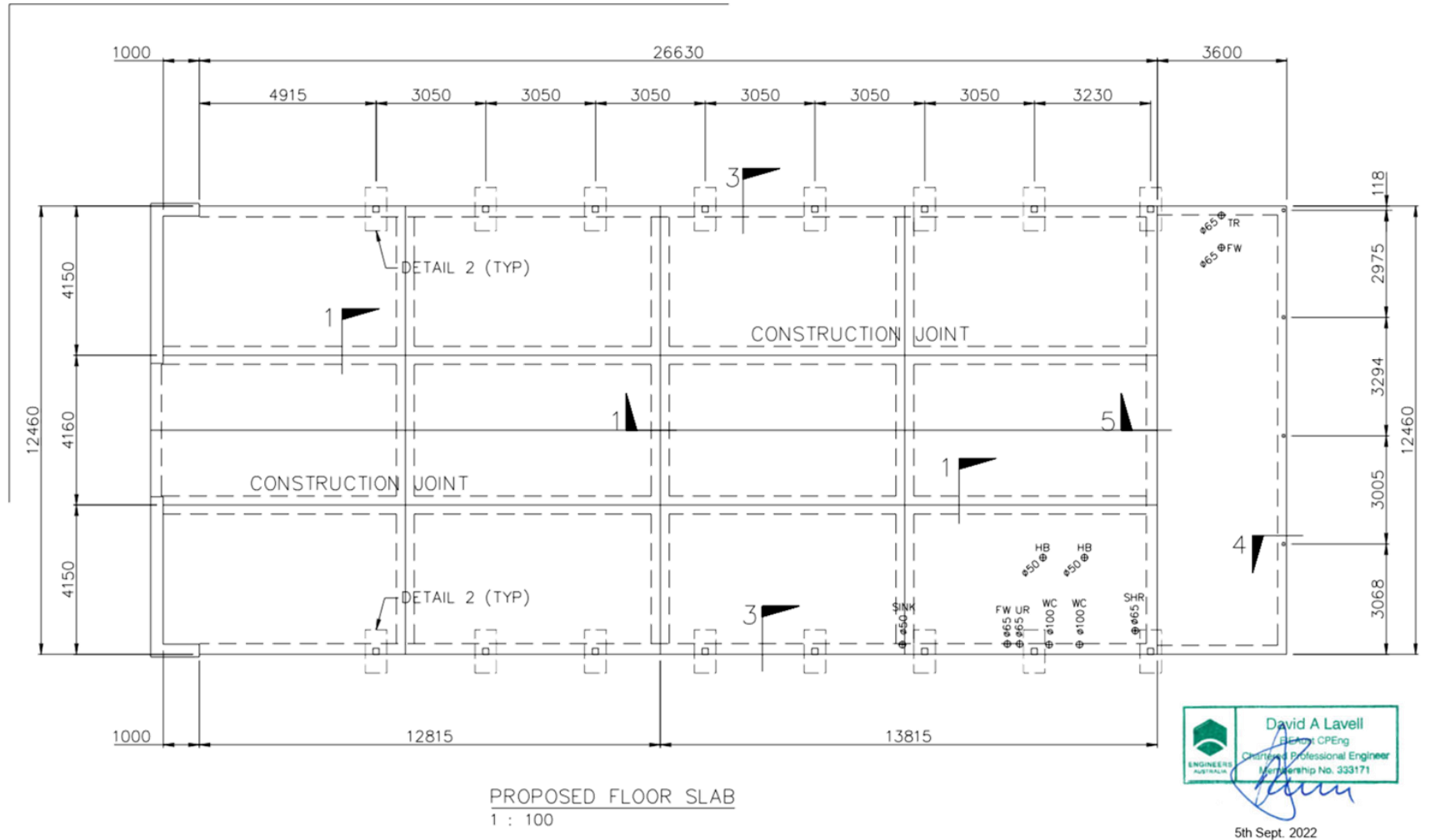

		 <p>PINEFIELD'S OF YORK RENOVATIONS</p> <p>GARY W. BYFIELD PO BOX 326 YORK W.A. 6302 MOBILE 0414 885 338 EMAIL gwb151@gmail.com</p>	<p>CLIENT :</p> <p>J. and R. MARWICK 7 JOAQUINA STREET YORK WA 6302</p>	<p>NORTH</p> 	CONCRETE DETAILS				
					DRAWN	GWB	SCALE	1 : 100	
A					ISSUED FOR REVIEW	DATE	JUN 22	REVISION	A
REVISION					DATE	JOB No	30-21/22	SHEET	10 A3

**SY002-01/23 RECRUITMENT OF A SENIOR OFFICER - EXECUTIVE MANAGER
INFRASTRUCTURE AND DEVELOPMENT SERVICES**

File Number:	4.3167
Author:	Chris Linnell, Chief Executive Officer
Authoriser:	Chris Linnell, Chief Executive Officer
Previously before Council:	Nil
Appendices:	Nil

NATURE OF COUNCIL'S ROLE IN THE MATTER

Executive

PURPOSE OF REPORT

As required under Section 2.1(a) of Policy G2 - Organisational Structure and Designation of Senior Staff, this report presents Council with a recruitment process for the role of Executive Manager Infrastructure and Development Services (EMIDS) for consideration.

BACKGROUND

Following the resignation of Ms Sinead McGuire from the position of EMIDS the Chief Executive Officer is starting a recruitment process to fill the vacancy.

COMMENTS AND DETAILS

The Chief Executive Officer will prepare a Request for Quote in accordance with Policy F2 - Procurement, to facilitate the recruitment process for the role of EMIDS. It is anticipated the recruitment process will take between four (4) to six (6) months to complete. The process for recruitment will involve the following steps:

1. Conduct a procurement process to source a suitably qualified and experienced Recruitment Consultant
2. Advertising of the role in print and online forums.
3. Recruitment Consultant to prepare a shortlist of applicants for interview which is provided to the Chief Executive Officer.
4. The Chief Executive Officer, Executive Manager Corporate & Community Services and Recruitment Consultant to interview the shortlisted applicants.
5. Referee and qualifications checks are to be undertaken by Recruitment Consultant.
6. Recommendation Report provided to the Chief Executive Officer by the Recruitment Consultant.

When the process outlined above has been completed, the Chief Executive Officer will provide a report to Council on the appointment of the preferred candidate in accordance with Section 5.37 of the *Local Government Act 1995*.

As the recruitment process will take some time and when layered with the current workload set out in the 2022/23 budget it is recommended that immediate support is brought into the Shire of York Executive via the use of an Acting EMIDS. This will allow for a considered recruitment process to be undertaken. Depending upon the arrangements negotiated for this infill, costs may include salary, accommodation, subject matter expert support and agency fees.

In undertaking the recruitment process, the principles affecting employment by a local government as contained in Section 5.40 of the *Local Government Act 1995* will be used as guidance.

OPTIONS

Council has the following options:

- Option 1:** Council can choose to direct the Chief Executive Officer to undertake the recruitment process in-house. However, due to the position being a Designated Senior Officer in accordance with Section 5.37(2) of the *Local Government Act 1995* this could be considered to cloud the transparency and independence of the process. Council directs the Chief Executive Officer to employ an interim EMIDS.
- Option 2:** Council can choose to direct the Chief Executive Officer to undertake the recruitment process through an external consultant to maintain the transparency and independence of the process and directs the Chief Executive Officer to employ an interim EMIDS.

Option 2 is the recommended option.

IMPLICATIONS TO CONSIDER

Consultative

Executive Leadership Team

Strategic

Strategic Community Plan 2020-2030

Goal 5: Strong Leadership and Governance

To have effective and responsive leadership and governance, where a sense of collective purpose and shared direction combine to work together.

Policy Related

F2 Procurement

G2 Organisational Structure and Designation of Senior Staff

Financial

It is proposed that funds for the interim EMIDS will be allocated from GL 042109 – Administration Salaries. This budget is underspent due to the delay in recruitment for several positions that were budgeted in the 2022/23 financial year, for example, the Graduate Engineers. The advertising costs for the recruitment process can be allocated to GL 042169 – Consultant Fees and are within current budget allocations. GL 042169 will be evaluated during the Mid-Year Budget Review process and any adjustments made to accommodate subject matter expert assistance required as a result of interim acting arrangements.

When a preferred applicant for the role of EMIDS is presented to Council as required under Policy G2 a salary package will also be presented by the Chief Executive Officer that will be within budget allocations and will align with the package advertised as part of the recruitment process. Reimbursement of relocation expenses will also be offered with clauses relating to repayment of these costs in the event of departure included in the contract of employment.

Legal and Statutory

Sections 5.37, 5.39 and 5.40 of the *Local Government Act 1995* are applicable and state:

“5.37. Senior employees

- (1) *A local government may designate employees or persons belonging to a class of employee to be senior employees.*

- (2) *The CEO is to inform the council of each proposal to employ or dismiss a senior employee, other than a senior employee referred to in section 5.39(1a), and the council may accept or reject the CEO's recommendation but if the council rejects a recommendation, it is to inform the CEO of the reasons for its doing so.*
- (3) *Unless subsection (4A) applies, if the position of a senior employee of a local government becomes vacant, it is to be advertised by the local government in the manner prescribed, and the advertisement is to contain such information with respect to the position as is prescribed.*
- (4A) *Subsection (3) does not require a position to be advertised if it is proposed that the position be filled by a person in a prescribed class.*
- (4) *For the avoidance of doubt, subsection (3) does not impose a requirement to advertise a position where a contract referred to in section 5.39 is renewed."*

“5.39. Contracts for CEO and senior employees

- (1) *Subject to subsection (1a), the employment of a person who is a CEO or a senior employee is to be governed by a written contract in accordance with this section.*
- (1a) *Despite subsection (1) —*
 - (a) *an employee may act in the position of a CEO or a senior employee for a term not exceeding one year without a written contract for the position in which he or she is acting; and*
 - (b) *a person may be employed by a local government as a senior employee for a term not exceeding 3 months, during any 2 year period, without a written contract.*
- (2) *A contract under this section —*
 - (a) *in the case of an acting or temporary position, cannot be for a term exceeding one year;*
 - (b) *in every other case, cannot be for a term exceeding 5 years.*
- (3) *A contract under this section is of no effect unless —*
 - (a) *the expiry date is specified in the contract; and*
 - (b) *there are specified in the contract performance criteria for the purpose of reviewing the person's performance; and*
 - (c) *any other matter that has been prescribed as a matter to be included in the contract has been included.*
- (4) *A contract under this section is to be renewable and subject to subsection (5), may be varied.*
- (5) *A provision in, or condition of, an agreement or arrangement has no effect if it purports to affect the application of any provision of this section.*
- (6) *Nothing in subsection (2) or (3)(a) prevents a contract for a period that is within the limits set out in subsection 2(a) or (b) from being terminated within that period on the happening of an event specified in the contract.*
- (7) *A CEO is to be paid or provided with such remuneration as is determined by the Salaries and Allowances Tribunal under the Salaries and Allowances Act 1975 section 7A.*
- (8) *A local government is to ensure that subsection (7) is complied with in entering into, or renewing, a contract of employment with a CEO."*

“5.40. Principles affecting employment by local governments

The following principles apply to a local government in respect of its employees —

- (a) *employees are to be selected and promoted in accordance with the principles of merit and equity; and*

- (b) *no power with regard to matters affecting employees is to be exercised on the basis of nepotism or patronage; and*
- (c) *employees are to be treated fairly and consistently; and*
- (d) *there is to be no unlawful discrimination against employees or persons seeking employment by a local government on a ground referred to in the Equal Opportunity Act 1984 or on any other ground; and*
- (e) *employees are to be provided with safe and healthy working conditions in accordance with the Work Health and Safety Act 2020; and*
- (f) *such other principles, not inconsistent with this Division, as may be prescribed.”*

Risk Related

The risks associated with recruitment relate to the ability to recruit appropriately skilled, experienced, and qualified staff. The decision to engage a recognised and respected recruitment consultant is designed to mitigate this risk.

Workforce

This position is a Senior Designated Officer.

VOTING REQUIREMENTS

Absolute Majority: No

RESOLUTION 020123

Moved: Cr Ashley Garratt

Seconded: Cr Kevin Trent

That, with regard to the recruitment of the Executive Manager Infrastructure and Development Services, Council:

- 1. Resolves to support the request from the Chief Executive officer to employ an interim Executive Manager Infrastructure and Development Services during the recruitment process in accordance with Section 5.39(1a) of the *Local Government Act 1995*.**
- 2. Notes that the Chief Executive Officer will negotiate the terms with an interim Executive Manager Infrastructure and Development Services.**
- 3. Resolves to engage a Recruitment Consultant to support the recruitment process for the Executive Manager Infrastructure and Development Services.**
- 4. Notes that the Chief Executive Officer will present a report back to Council with a recommendation for the appointment of the Executive Manager Infrastructure and Development Services as a Designated Senior Officer in accordance with Section 5.37(2) of the *Local Government Act 1995*.**

CARRIED: 5/0

8 CLOSURE

The Shire President thanked everyone for their attendance and closed the meeting at 5.19pm.

The minutes were confirmed by the Council as a true and accurate record at the Council Meeting held on 28 February 2023.

*SHIRE PRESIDENT
Cr Denese Smythe*